



atom

A technical diagram of a semi-circular fiberglass pool. The pool's interior is filled with a grid of small circles. The outer edge features a series of larger, teardrop-shaped openings. A small upward-pointing arrow is located near the top center of the pool's rim.

**FIBERGLASS POOLS**

ULTRA COMPACT NICHE LIGHT

**INSTALLATION &  
OWNER'S MANUAL**



# CONTENTS

READ THIS FIRST	5
TOOLS REQUIRED	6
PRODUCT SUPPORT AND INFORMATION	6
INCLUDED PARTS	7
FINISHED INSTALLATION	8
INSTALLATION INSTRUCTIONS	9
LIGHT ASSEMBLY	11
WINTERIZATION	12
CABLE ADJUSTMENT & REMOVAL	14
KEY DIMENSIONS	16
TROUBLESHOOTING	17
ELECTRICAL GROUNDING / FCC COMPLIANCE	18



## NOTICE

**FRESH WATER USE ONLY  
HORIZONTAL MOUNT ONLY  
NOT INTENDED FOR OPERATION OUT OF WATER**

**FOR SUPPLY CONNECTION, USE ONLY AN ISOLATING LOW VOLTAGE POWER SUPPLY WITH UNGROUNDED OUTPUT, EVALUATED FOR SWIMMING POOL USE**



# READ THIS FIRST

Congratulations on your purchase of the **ATOM** underwater lighting system. All **ATOM** lights are manufactured by Spa Electrics in Australia from only the highest quality materials. For more information about Spa Electrics & our products, please visit [www.spaelectrics.ca](http://www.spaelectrics.ca)

## BEFORE YOU START:

- Cables can be shortened to suit individual installation requirements. Spa Electrics recommends all cabling is protected by conduit and that a junction box (or similar) is incorporated into pool cabling design to avoid siphoning.
- Ensure that the lighting system is installed by a qualified person (e.g. registered pool builder and/or licensed electrician), in accordance with the most current edition and/or amendment of current NEC wiring code.
- For safe and proper installation, ensure that only those parts supplied with the system are used.
- Maximum installation depth for the **ATOM** light is 1.2ft (14") below water line (to top of light).
- The **ATOM** light must be correctly installed in or on the wall of the pool with the top of the lens no less than 4" below the nominal water level.
- All lights should be mounted in a location that is easily accessible without the need for entering or lowering the pool water.
- 20" cable has been supplied pre-assembled within niche assembly, and must remain stored within the Niche to ensure the light can be accessed above the waterline. [Maximum cable within niche = 24" (18AWG & 16AWG). See Page 16 for more information].
- USE of neutral cure silicone only. **DO NOT** USE acid curing silicone or Sikaflex adhesive.

## CLEANING

- Only use warm water and a soft brush or cloth to clean **ATOM** lights. **DO NOT** use detergents or spirits as this can damage the light and void your warranty.

## USE

- **DO NOT** operate light unless completely submerged in water.
- Operating the light for at least 15 minutes every week is advised (all year round).
- **ATOM** lights are suited for both domestic and commercial installations and can be operated continuously (24/7) if required.
- Temperature range for installation, operation and servicing: +32°F ~ +104°F (0°C ~ +40°C)



## IMPORTANT NOTE

**The ATOM light must only be used with a UL listed 12V AC power supply or a power source intended for swimming pool use (not included).**

**Minimum power source wattage requirement - 15 Watts per light.**

- DO NOT use electronic or switch-mode power supplies with ATOM lights. These power supplies will damage the light and void your product warranty.
- Pool chemicals & PH levels: Due to the corrosive nature of unbalanced pool chemicals, Spa Electrics strongly recommend that your pool water is balanced prior to installing your pool lights or any plastic or stainless steel components, and tested weekly to maintain these levels. pH levels should be maintained between 7.2 – 7.6 at all times to ensure the longevity of these components.
  - > Failure to do so can result in chemical damage to the light housing and pool fittings, including stainless steel components.
  - > Please note: Lights or components found to have excessive chemical damage will not be covered under our manufacturer's warranty policy.
- This light contains no user-serviceable parts; opening the light will void the product warranty.

# TOOLS REQUIRED

- 2 5/8" ~ 2 3/4" Hole saw
- No. 2 Phillips screwdriver (for light-head removal)
- Flat-blade screw driver (for light-head removal)



## IMPORTANT NOTES

- The use of power tools during installation is **not** recommended as these devices can cause faults and damage to light components.
- All installation steps should be carried out with manual tools only.
- The enclosed images are for illustrative purposes only. Appearances of parts and assemblies may vary from the enclosed illustrations.
- Please contact your reseller if you have any questions regarding the correct installation of this product.



## WINTERIZATION

- Lights must be removed from pool wall and cable disconnected via plug connection & stored in a safe place.
- Terminal Cover must be fitted to Plug Top prior to reinstalling into niche for winter.
- Unless niche/conduit connection is adequately sealed (i.e. via included cable gland components), pool water level must be drained down 12" below the lowest light(s) position in pool wall.
- All conduits should be checked for accumulated water and drained if required.
- Consult your local pool professional for complete pool winterization process.

## PRODUCT SUPPORT & INFORMATION

For the most update to date installation information and contact information for assistance in your region, please visit [www.spaelectrics.com](http://www.spaelectrics.com)

# INCLUDED PARTS

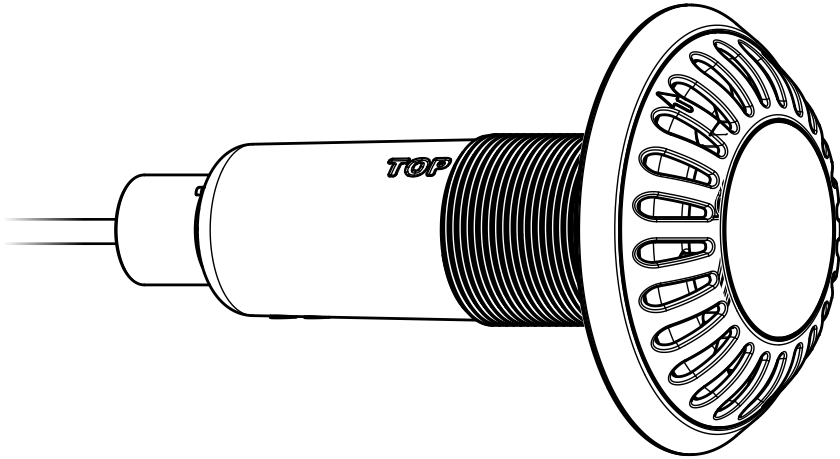

LIGHT, CABLE & NICHE ASSEMBLY

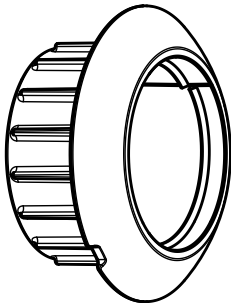

CONICAL  
NUT

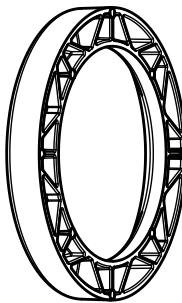

CONICAL  
WASHER

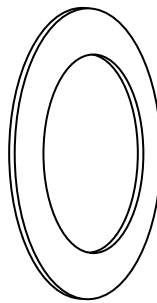

FLAT  
WASHER



TERMINAL  
COVER



1x WARRANTY CARD



1x INSTALLATION MANUAL



## REQUIRED PART (NOT INCLUDED)

**UL LISTED 12V AC POWER SUPPLY OR POWER SOURCE INTENDED FOR SWIMMING POOL USE.**

Minimum power source wattage requirement - 15 Watts per light

Spa Electrics recommends the use of the "LVX" series safety transformers with it's ATOM lighting range for more information visit [www.spaelectrics.com](http://www.spaelectrics.com)

# FINISHED INSTALLATION

## STANDARD WALL MOUNTING

Depending on your installation requirements, conduits may run to a common junction box or return directly to the power supply. In either case, it is imperative that the conduit extends above the water level of the pool at some point in order to prevent siphoning.

**NOTE:** Conduit should contain a draw-wire to allow easy installation of power cable.

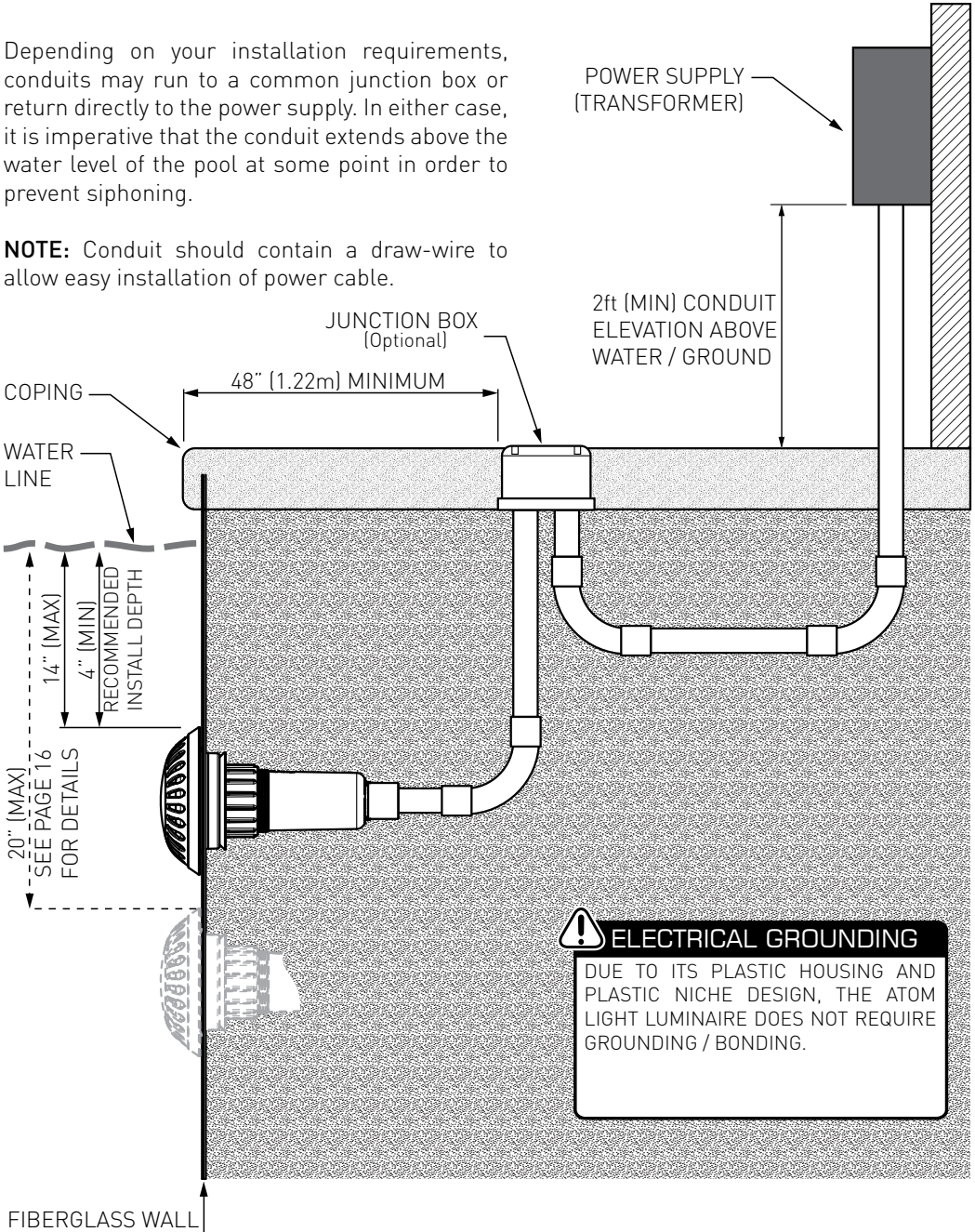

# INSTALLATION PROCEDURE

## 1 MOUNTING HOLE PREPARATION \*

\* MAY NOT BE REQUIRED IF PRE-PUNCHED / DRILLED HOLES AVAILABLE FOR LIGHT MOUNTING

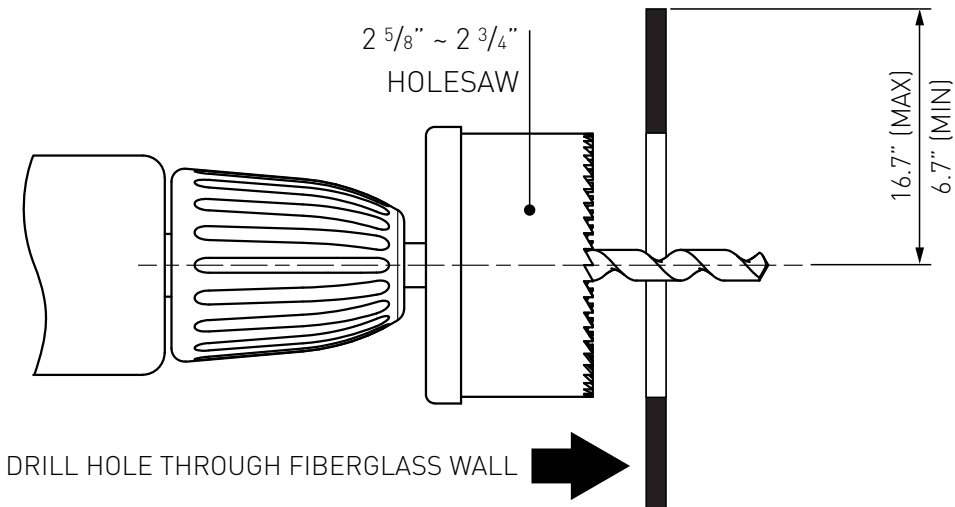

## 2 ORIENTATION OF NICHE "TOP"

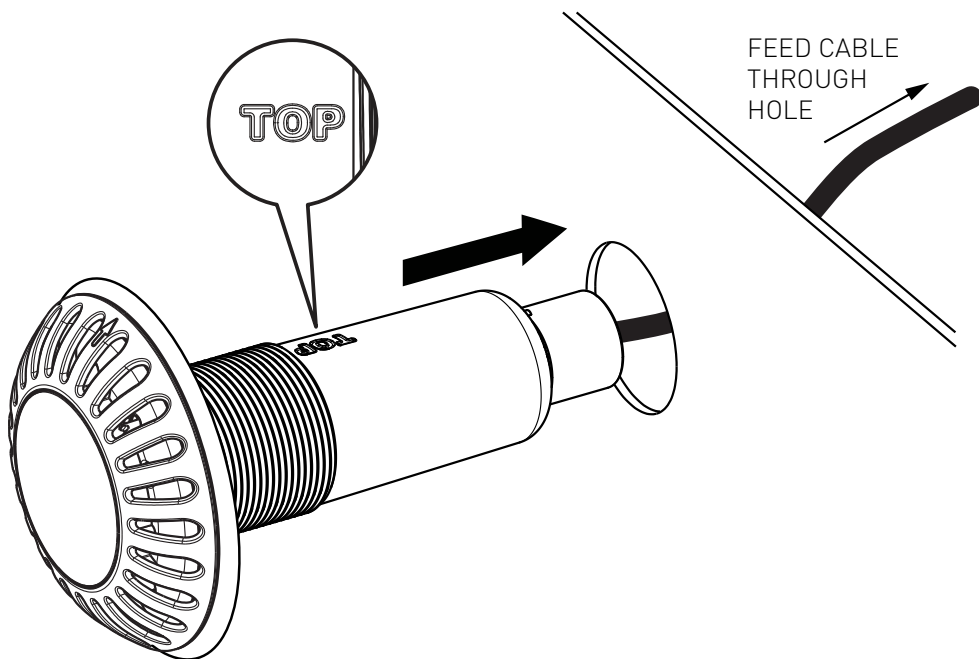

# 3

## ASSEMBLE WASHER AND NUT

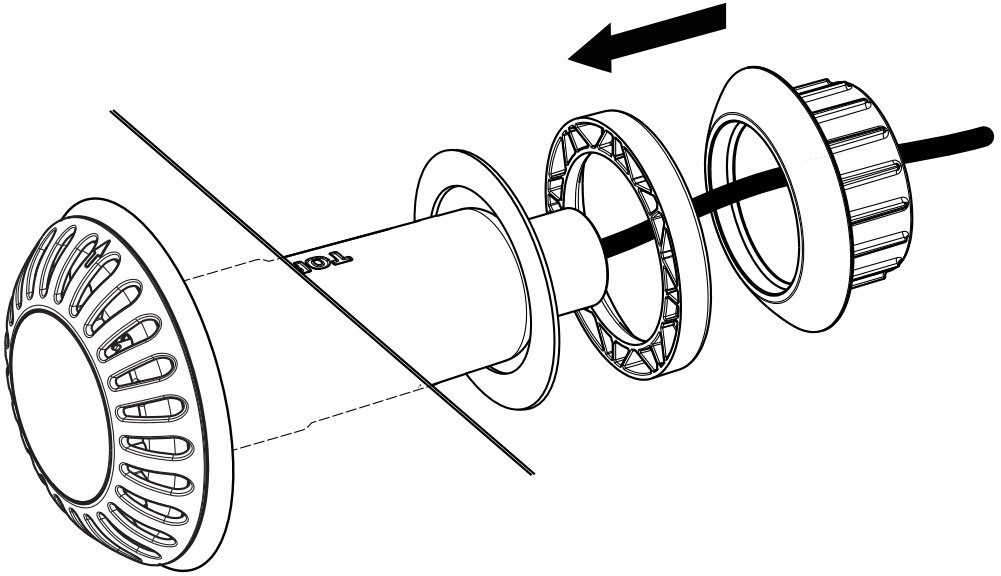

# 4

## APPLY SEALANT

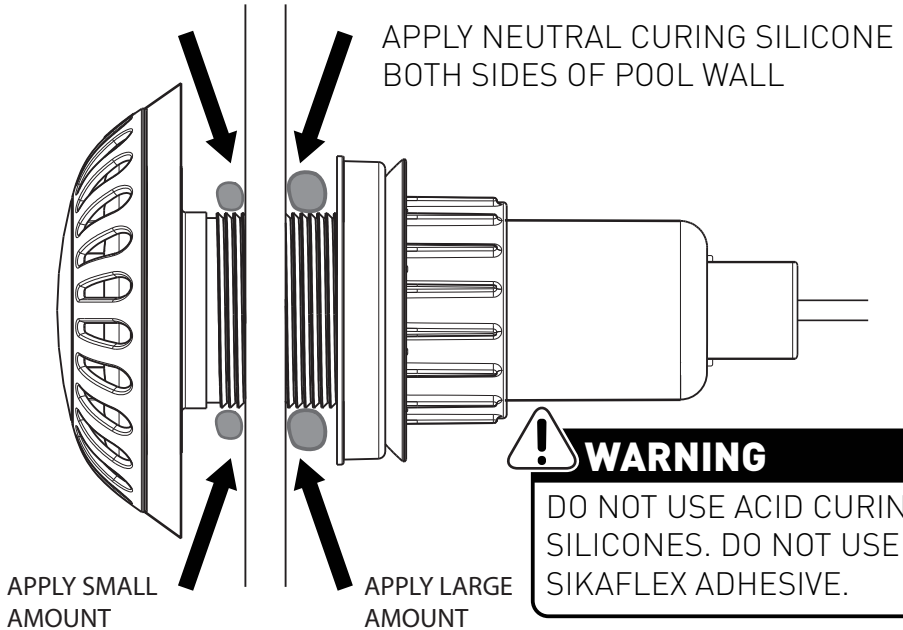

# 5

## TIGHTEN NUT

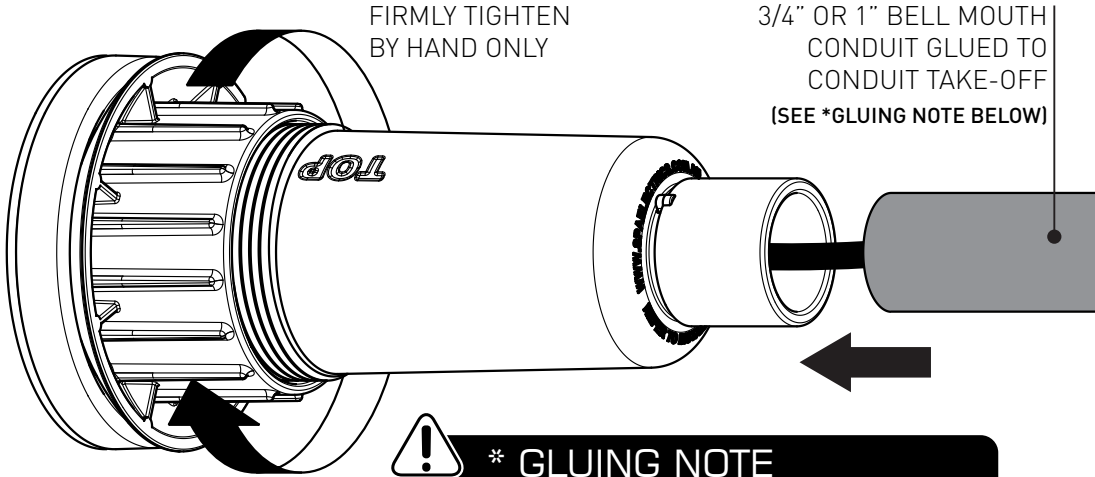

FIRMLY TIGHTEN  
BY HAND ONLY

3/4" OR 1" BELL MOUTH  
CONDUIT GLUED TO  
CONDUIT TAKE-OFF  
(SEE \*GLUING NOTE BELOW)



### \* GLUING NOTE

ENSURE P.V.C. SOLVENT CEMENT IS SUITABLE  
FOR NON-PRESSURE APPLICATIONS AND USE  
WITH A.B.S. PLASTIC

# WINTERIZATION

## LIGHT REMOVAL

**1** PUSH & HOLD BUTTON WITH FLAT BLADE

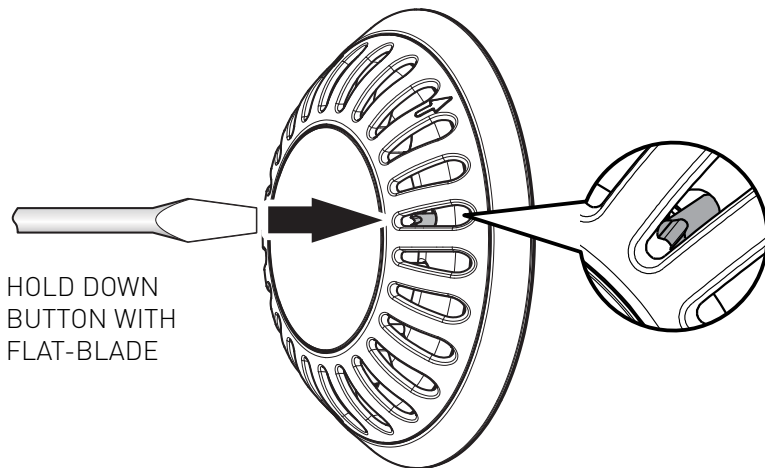

**2** ROTATE COUNTER-CLOCKWISE & REMOVE FROM LOCKING RING

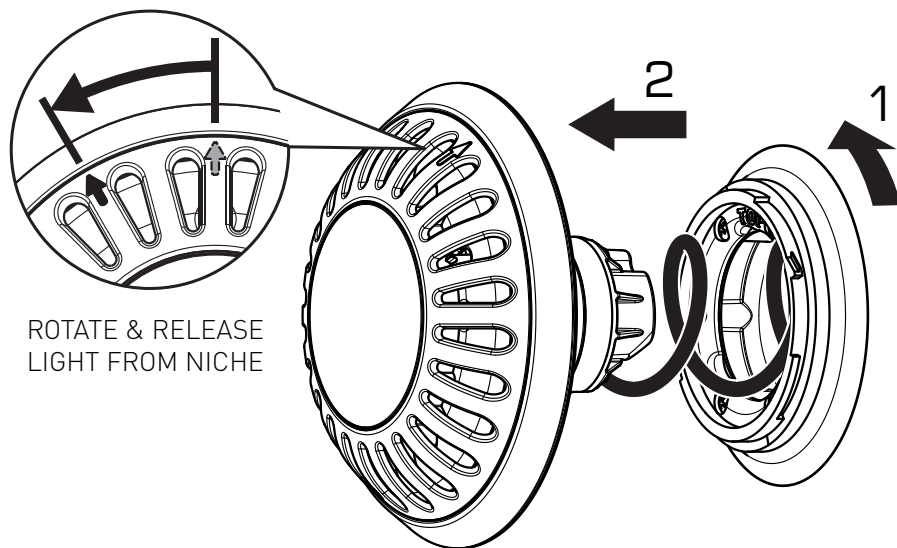

# WINTERIZATION

## PLUG REMOVAL & TERMINAL COVER ATTACHMENT

### 3 REMOVE PLUG FROM LIGHT

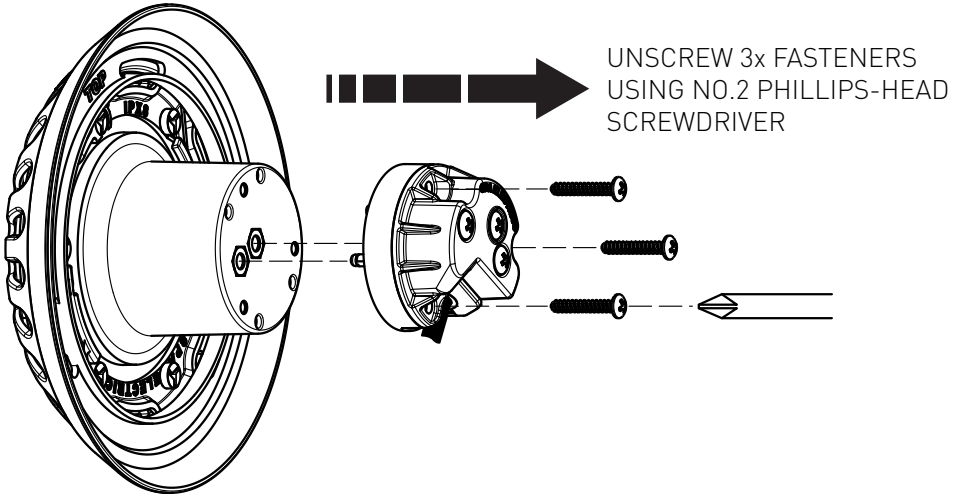

### 4 ASSEMBLE TERMINAL COVER TO PLUG & STORE IN NICHE

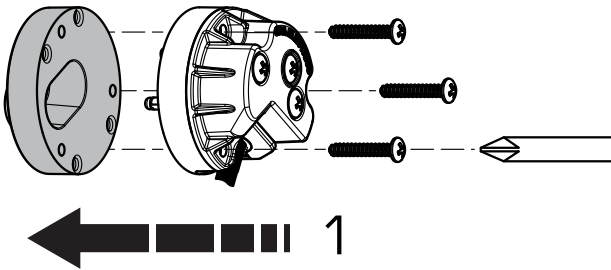

1 ASSEMBLE TERMINAL COVER TO PLUG  
USING NO.2 PHILLIPS-HEAD SCREW-  
DRIVER

2 [RECOMMENDED] STORE PLUG WITHIN  
NICHE DURING WINTER PERIOD

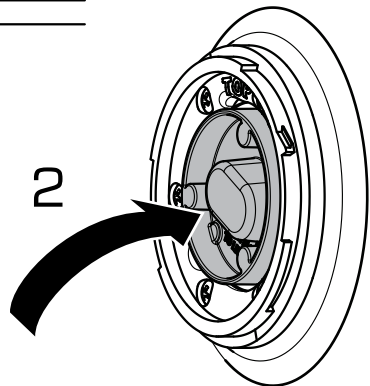

# CABLE ADJUST / REMOVAL

ATOM lights (for fibreglass pools) are supplied with 20" of cable pre-installed within the niche. In circumstances where additional cable-length is required, the cable can be extended to a maximum of 24" and stored within the niche. (Applicable for both 18AWG and 16AWG cables).

The following diagrams illustrate how the cable can be adjusted and/or removed:

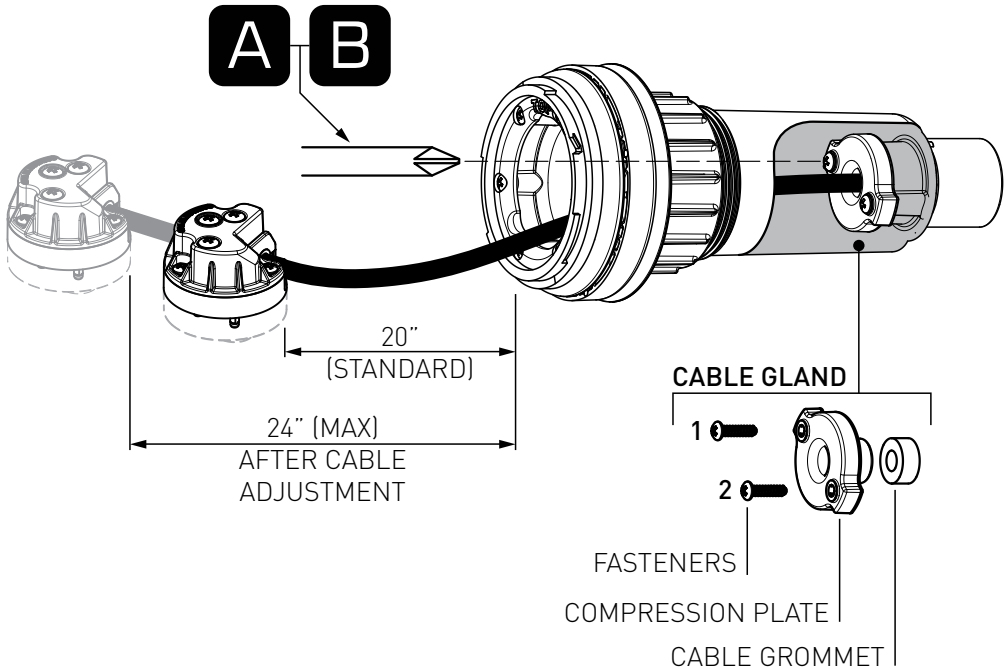

## A CABLE ADJUSTMENT

USING A NO. 2 PHILLIPS-HEAD SCREW-DRIVER, PARTIALLY LOOSEN FASTENERS 1 & 2 TO ALLOW CABLE TO SLIP THROUGH NICHE.

DO NOT EXTEND CABLE LONGER THAN 24" (SEE ABOVE) - EXCESS CABLE WITHIN NICHE WILL RESTRICT CORRECT ASSEMBLY OF LIGHT HEAD.

## B CABLE REMOVAL

USING A NO. 2 PHILLIPS-HEAD SCREW-DRIVER, COMPLETELY REMOVE **CABLE GLAND** COMPONENTS AND STORE SAFELY FOR LATER-USE.

ENSURE **CABLE-GLAND** COMPONENTS ARE RE-ASSEMBLED TO CABLE IN THE ORIENTATION & ORDER SHOWN ABOVE PRIOR TO FASTENING BACK INTO NICHE.

# CABLE ADJUST / REMOVAL

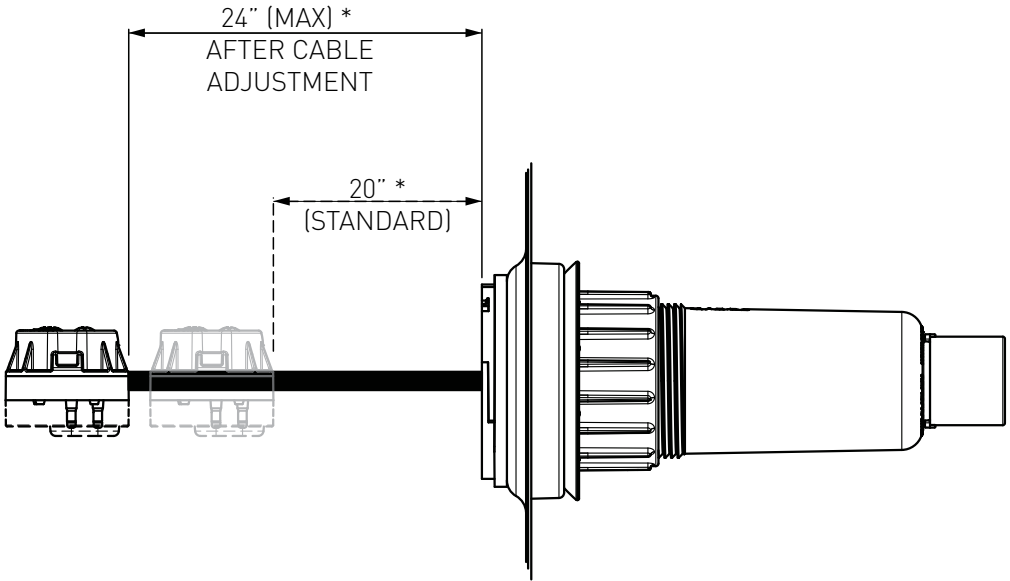

## \* CABLE LENGTH

CABLE LENGTH MEASURED FROM  
FRONT OF CLAMP RING TO PLUG'S  
CABLE-ENTRY POINT



## NOTE

ALWAYS ENSURE POOL LIGHT CAN  
BE RAISED ABOVE WATERLINE FOR  
WINTERIZATION & SERVICING



## IMPORTANT NOTES

- DO NOT OVERTIGHTEN SCREWS WHEN RE-ASSEMBLING CABLE-GLAND COMPONENTS INTO NICHE.
- DO NOT USE POWER-TOOLS
- DO NOT ADD SEALANTS, GREASES OR ADHESIVES TO CABLE OR CABLE-GLAND COMPONENTS AT ANY TIME.
- ENSURE ALL SURFACES ARE CLEAN AND DRY PRIOR TO CABLE & CABLE-GLAND INSTALLATION
- **DO NOT ASSEMBLE / DISASSEMBLE UNDERWATER**

# KEY DIMENSIONS

## A NICHE

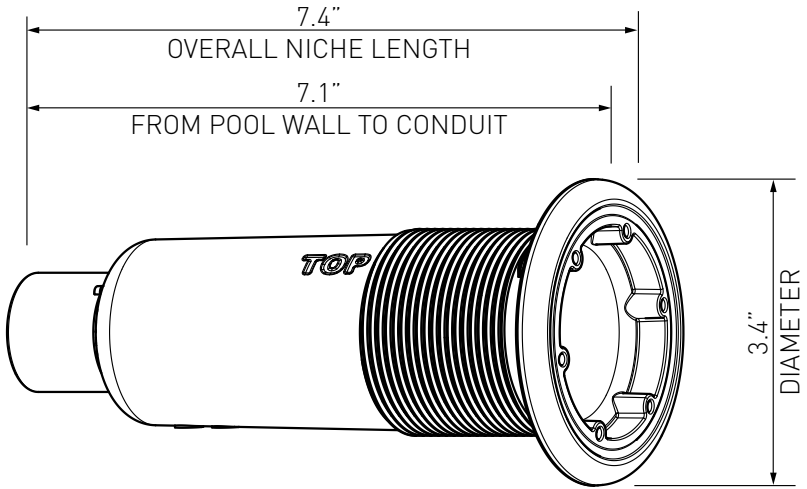

## B INSTALLED LIGHT

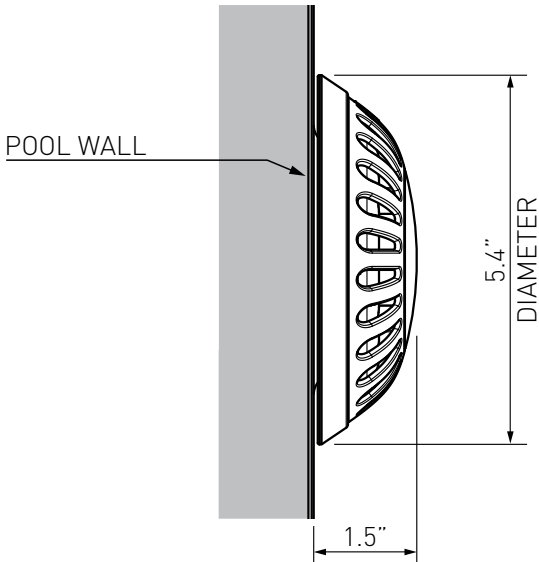

# TROUBLESHOOTING

ISSUE	REASON	ACTION
Light returns to WHITE colour during manual colour change.	Light synchronization process has been triggered.	Refer to MULTI-PLUS User Guide. (Pg. 3)
Light flashes (RED)	Light over heating	Check light is fully submerged. Check vents are not obstructed
Light not operating (1)	Faulty connection to transformer	Ensure cable correctly connected to transformer terminals
Light not operating (2)	Mains power not connected	Check transformer is plugged in to GPO and switched on
Light not operating (3)	Damaged cable	Disconnect plug top and test voltage under load using multi-meter (ie. 20w 12v)
Light not operating (4)	Transformer not working	Check fuses & test transformer using multimeter under load (ie. 15W 12V)
Light colours not synchronized	Incorrect operating mode selected.	Refer to MULTI PLUS setup procedure (pg. 3)

**If these issues cannot be resolved with the above recommended actions, please contact your local Spa Electrics reseller or Spa Electrics directly.**

Phone: 1-855-881-0889 (business hours)

Email: [info@selectpoolproducts.ca](mailto:info@selectpoolproducts.ca)

Web: [www.spaelectrics.com](http://www.spaelectrics.com)

# ELECTRICAL GROUNDING

## Underwriters Laboratories (UL) Statement

Per the NEC, NFPA 70, Article 680.23 (B)(5), states that bonding shall not be required for luminaires that are listed for the application and have no non-current carrying metal parts. In addition, per Article 680.26 (B)(4), exception states that Listed low-voltage lighting systems with non-metallic forming shells shall not require bonding.

Therefore, luminaires with polymeric/non-current carrying metal parts are not required to be grounded / bonded.

## Manufacturers Statement

Spa Electrics ATOM & QUANTUM (EM & WN9) luminaires with their plastic housing designs and plastic niches do not require grounding / bonding.

Spa Electrics ATOM & QUANTUM (EM & WN9) lights have also been determined to comply with the applicable requirements for wet-niche, LED type Swimming Pool and Spa Luminaires.

# FCC COMPLIANCE STATEMENT

This device complies with part 15 of the FCC rules. Operation is subject to the following two (2) conditions:

- (1) This device may not cause harmful interference, and
- (2) this device must accept any interference received, including interference that may cause undesired operation.

**Note:** This equipment has been tested and found to comply with the limits for a Class B digital device, pursuant to part 15 of the FCC Rules. These limits are designed to provide reasonable protection against harmful interference in a residential installation. This equipment generates, uses and can radiate radio frequency energy and, if not installed and used in accordance with the instructions, may cause harmful interference to radio communications. However, there is no guarantee that interference will not occur in a particular installation. If this equipment does cause harmful interference to radio or television reception, which can be determined by turning the equipment off and on, the user is encouraged to try to correct the interference by one or more of the following measures:

- Reorient or relocate the receiving antenna.
- Increase the separation between the equipment and receiver.
- Connect the equipment into an outlet on a circuit different to that to which the receiver is connected.
- Consult the dealer or an experienced radio / TV technician for help.

**Do not make any changes or modifications to the equipment unless otherwise specified in the manual.**





## NOTE

PLEASE STORE THIS  
MANUAL IN A SAFE PLACE  
FOR FUTURE REFERENCE



Proudly manufactured by

**Spa Electrics**



[www.spaelectrics.com](http://www.spaelectrics.com)

© COPYRIGHT 2024 SPA ELECTRICS PTY. LTD.  
ALL RIGHTS RESERVED

US 20240410