

T1 003

PLUG ASSEMBLY INSTALLATION GUIDE

BEFORE YOU START

ENSURE THAT ALL POWER TO EXISTING LIGHTS ARE SWITCHED OFF.

INCLUDED PARTS

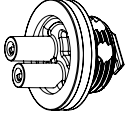

Screw Terminal
End
(screws attached)

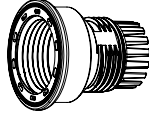

Connector
Barrel



Glands
(2 sizes)

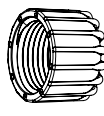

Gland Nut

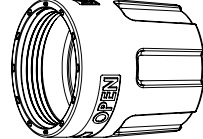

Plug
Collar

1 CABLE PREPARATION

ALL CABLE CONNECTIONS ARE TO BE DONE AT SURFACE LEVEL, AND OUT OF WATER.

STRIP POWER CABLE TO SPECIFIED LENGTH.

NOTE



IF CABLE LENGTH ALLOWS,
CUT CABLE BACK UNTIL
FRESH COPPER APPEARS.

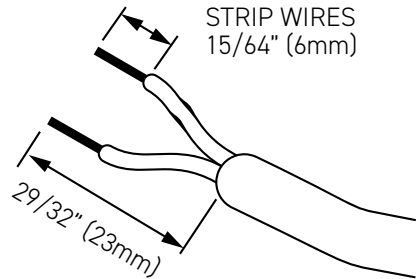

2 START ASSEMBLY OF CONNECTOR PLUG

FEEED THE PLUG COLLAR
ONTO THE CABLE, THEN
FEEED THE GLAND NUT ONTO
THE CABLE.

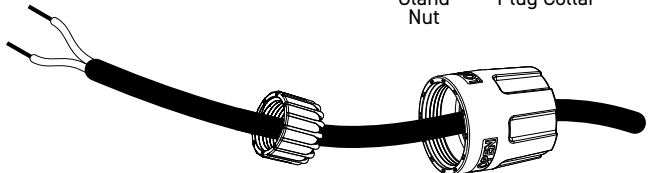
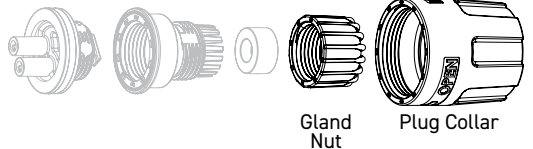

3 CABLE GLAND

SELECT THE APPROPRIATELY SIZED CABLE GLAND FROM THE 2 INCLUDED SIZES.

FEED THE CABLE GLAND ONTO THE CABLE.

THE GLAND FITMENT SHOULD BE FIRM OVER THE CABLE WITHOUT BULGING OR DEFORMING THE GLAND.

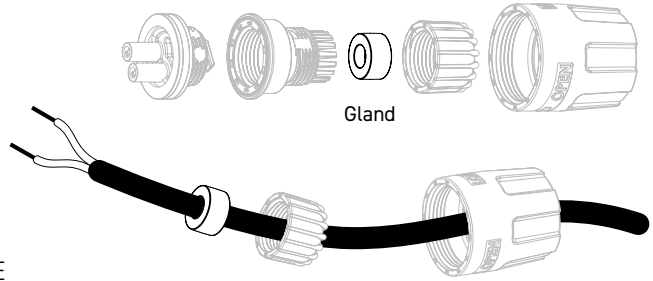

4 CONTINUE ASSEMBLY OF CONNECTOR PLUG

FEED THE CONNECTOR BARREL ONTO THE CABLE.

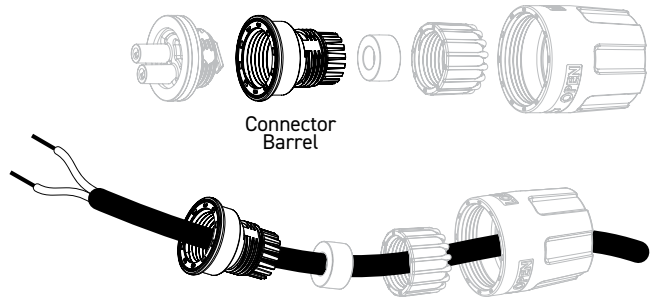

5 CONNECT THE SCREW TERMINAL END

- 1: USING A FLAT BLADE SCREWDRIVER, LOOSEN THE TWO (2) FASTENERS ON THE SCREW TERMINAL END. DO **NOT** FULLY REMOVE THE TWO FASTENERS.

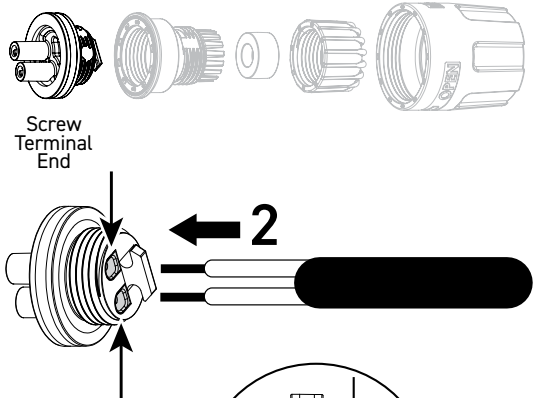
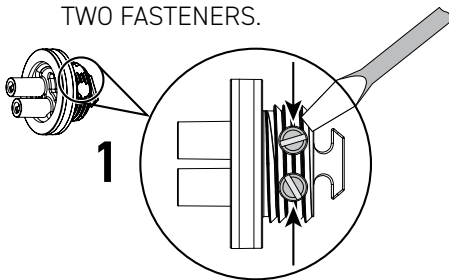

- 2: FEED THE TWO STRIPPED CABLE ENDS THROUGH THE TWO HOLES IN THE BACK OF THE SCREW TERMINAL END.
- 3: USE A FLAT BLADE SCREWDRIVER TO RE-TIGHTEN THE TWO (2) FASTENERS.

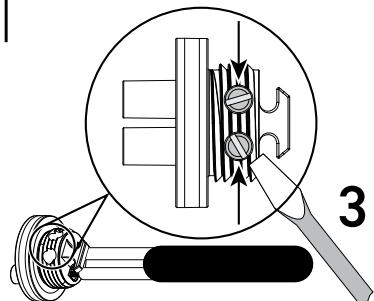

6 STRAIN RELIEF

ADJUST THE TWO CABLE ENDS SO THAT THEY SIT BEHIND THE STRAIN RELIEF POST AS SHOWN IN THE THREE ILLUSTRATIONS BELOW.

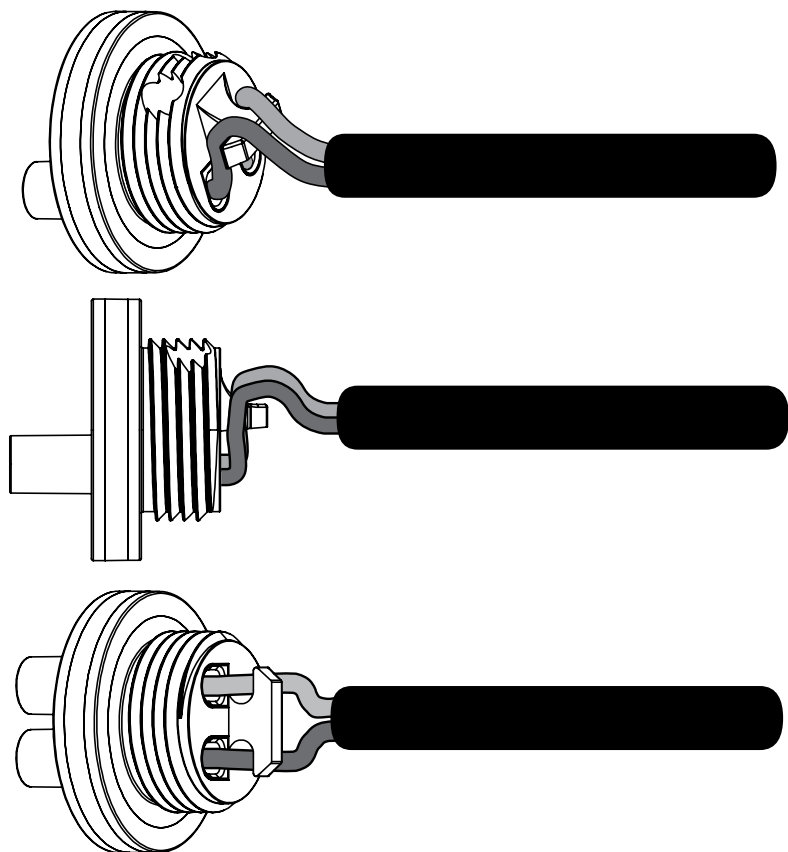

7 START ASSEMBLY OF CONNECTOR PLUG

CAREFULLY THREAD CONNECTOR BARREL ONTO SCREW TERMINAL AND TIGHTEN FIRMLY BY HAND.

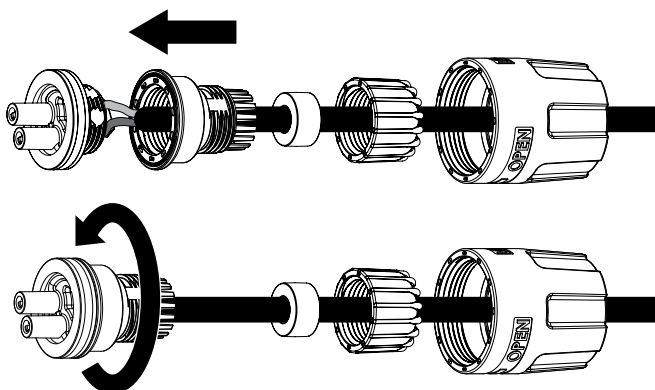

9 CONTINUE ASSEMBLY OF CONNECTOR PLUG

- 1: SEAT CABLE GLAND ALL THE WAY INTO CONNECTOR (DO A VISUAL CHECK TO MAKE SURE A SEAL BETWEEN GLAND AND CABLE).
- 2: CAREFULLY THREAD GLAND NUT ONTO CONNECTOR BARREL.
- 3: TIGHTEN GLAND NUT FIRMLY, BY HAND ONLY.

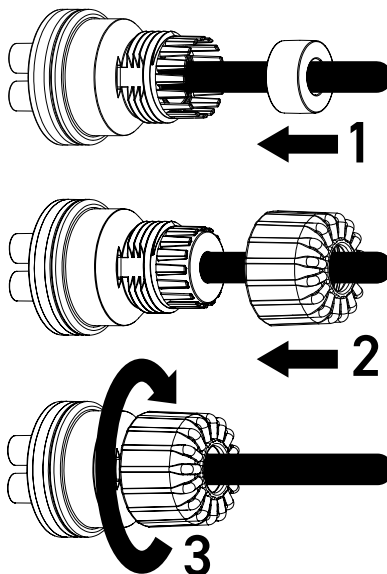

10 COMPLETE ASSEMBLY OF CONNECTOR PLUG

POSITION PLUG COLLAR ALL THE WAY TO THE END READY FOR ATTACHMENT TO THE LIGHT ASSEMBLY.

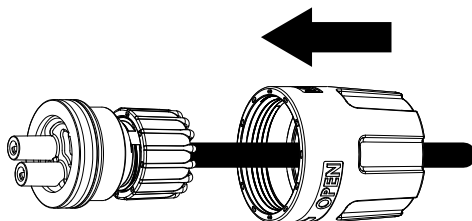

COMPLETED ASSEMBLY

