

# QUANTUM

HIGH PERFORMANCE LED NICHE LIGHT

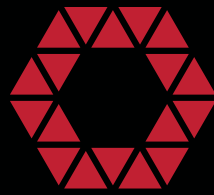

# QUANTUM

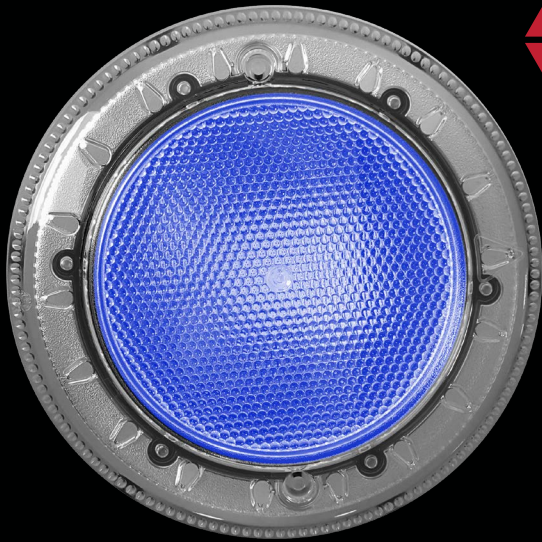

The **QUANTUM** Series from Spa Electrics, represents the culmination of over 40 years experience in underwater lighting design. Its robust design is sleek and unobtrusive, with its transparent facade allowing it to seamlessly blend into any pool design.

Featuring a host of technically advanced features, including an external heat sink for maximum cooling and LED longevity, detachable cable for hassle-free service and German engineered LED's and optics for superior light distribution and performance.

The **QUANTUM** Series is designed and manufactured in Australia and backed by Spa Electrics' industry leading customer care network. For more information on the **QUANTUM** Series and our other products, please visit [www.spaelectrics.com](http://www.spaelectrics.com).

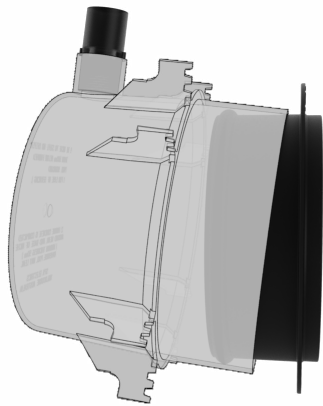

## SIMPLE INSTALLATION

Self-adjusting Leveling Ring ensures the light sits flush to the pool wall with a stylish, flush mount design



## BUILT SMART

The innovative Direct Connect Plug provides seamless installation and hassle-free servicing for years to come

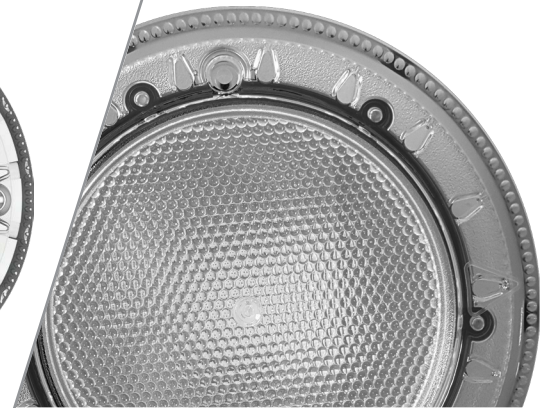

## BUILT POWERFUL

Maximize light performance with **QUANTUM's** combination of advanced optics and engineered components to deliver maximum efficient output

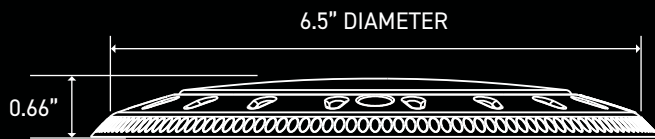

The **QUANTUM Series** is designed and manufactured in Australia and backed by Spa Electrics' industry leading customer care network.

For more information on the **QUANTUM Series** and our other products, please visit: [www.spaelectrics.com](http://www.spaelectrics.com)



### Production Specifications

VOLTAGE:	10.5 ~ 13v AC
WATTAGE:	12w
INGRESS PROTECTION:	IPX8
SUITABLE FOR:	Concrete Pools

### LED Color

MULTI PLUS	RGB+W	Varies	850lm
WHITE	White	4000k	850lm
BLUE	Blue	460nm	180lm

### LED Array

### Wavelength

### Lumens

### Hardware Specification

POOL CONTROLLERS:	Compatible with most major brand pool controllers
TRANSFORMER:	Compatible with LiTYARD 2 & LVX Series

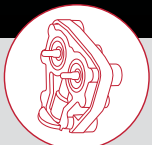

QUICK CONNECT PLUG



INDUSTRY LEADING BRIGHTNESS



STANDARD HOLE SIZE



YEAR SERVICE WARRANTY

**Spa Electrics**<sup>®</sup>

[spaelectrics.com](http://spaelectrics.com)



2023/01/16