

SE Spa Electrics®

retro

REPLACEMENT LED POOL LIGHT

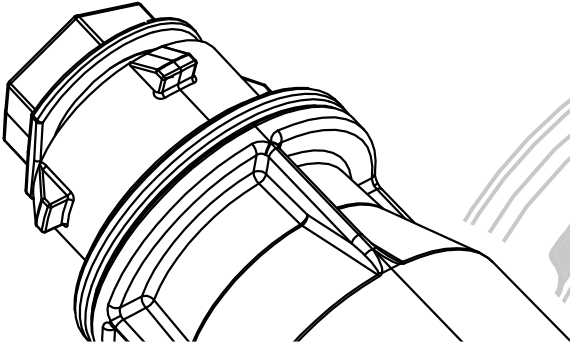

POOL LIGHT GLOBRITE INSTALL

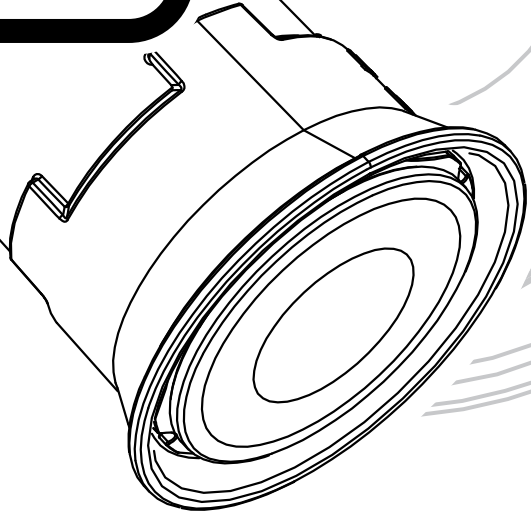

T1G

**R1 - GLOBRITE
INSTALLATION & OWNER'S MANUAL**

CONTENTS

READ THIS FIRST		5
TOOLS REQUIRED		6
INCLUDED PARTS		7
INSTALLATION	1: REMOVE EXISTING LIGHT	8
	2: GLOBRITE ADAPTER ASSEMBLY	9
	3: PLUG ASSEMBLY	13
	4: LIGHT ASSEMBLY	19
	5: FITMENT INTO EXISTING FITTING	22
WINTERIZATION		24
LIGHT REMOVAL		25
KEY DIMENSIONS		28
TROUBLESHOOTING		29
ELECTRICAL GROUNDING		30
FCC COMPLIANCE STATEMENT		30

IMPORTANT



A **12V AC** TRANSFORMER MUST BE INSTALLED.
DC POWER SUPPLIES ARE NOT COMPATIBLE.

NOTE



FRESH WATER USE ONLY
NOT INTENDED FOR OPERATION OUT OF WATER

PRE-INSTALLATION CHECK

1 CHECK POWER SUPPLY

SPA ELECTRICS **RETRO T1** LIGHTS **MUST** BE CONNECTED TO A 12V AC TRANSFORMER.

THOROUGHLY CHECK THE EXISTING POWER SUPPLY SETUP AND CONFIRM THE EXISTING TRANSFORMER MEETS REQUIREMENTS OUTLINED IN STEP 2.

IF NO TRANSFORMER IS CONNECTED, DO **NOT** PROCEED WITH INSTALLATION.

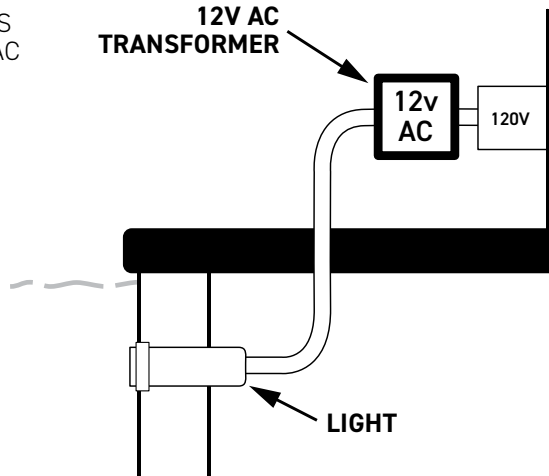

STOP!

DO **NOT** CONNECT THIS PRODUCT DIRECTLY TO 120V MAIN POWER.

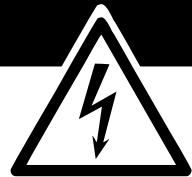

2 TRANSFORMER REQUIREMENTS

EXISTING TRANSFORMER MUST BE:

- UL Listed Isolating Low Voltage power supply, evaluated for swimming pool use
- Installed as per current NEC wiring rules
- 12~14v AC output
- Minimum 8w per **Retro T1** light
- In good working order

EXISTING TRANSFORMER MUST **NOT** BE:

- DC or 'LED Driver'
- Electronic or Switch mode
- Weather damaged or in otherwise poor condition

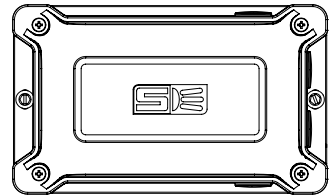

Spa Electric recommends "LVX" safety transformers for use with **Retro T1** lights

(LVX 50 & LVX 100)

PRE-INSTALLATION CHECK

3 CHECK CABLE THICKNESS

RETRO T1G IS DESIGNED TO FIT EITHER AN EXISTING GLOBRITE OR MICROBRITE CABLE.
GLOBRITE CABLE DIAMETER: ~ 23/64" (9mm)
MICROBRITE CABLE DIAMETER: ~ 19/64" (7.5mm)



4 CHECK FITTING TYPE

THIS SPA ELECTRICS RETRO T1G LIGHT IS DESIGNED TO BE INSTALLED IN A PENTAIR GLOBRITE FITTING.

SEE THE FOLLOWING ILLUSTRATIONS OF EXAMPLES FOR REFERENCE ONLY.

VINYL

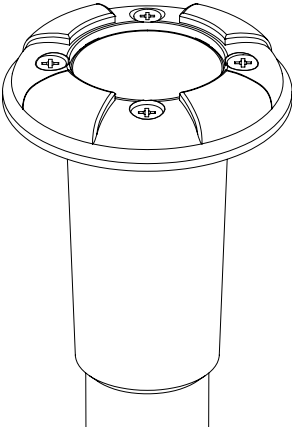

FIBERGLASS

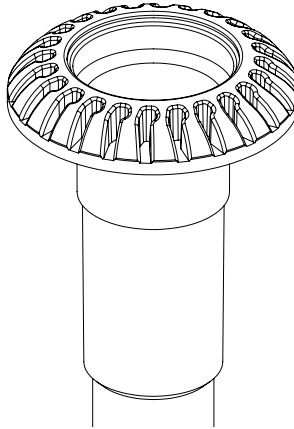

CONCRETE

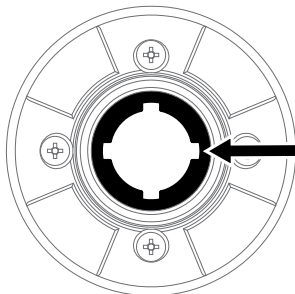
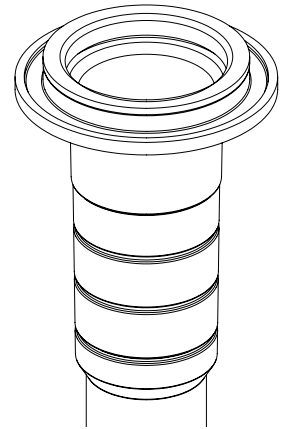

CHECK FOR THE REQUIRED FEATURE INSIDE THE FITTING TO CONFIRM COMPATIBILITY.

READ THIS FIRST

Congratulations on your purchase of a Spa Electrics **Retro T1** Series Pool Light. This light has been designed in conjunction with leading pool professionals across the USA and manufactured solely in Australia.

The **Retro T1** Series light is designed to quickly and easily replace existing LOW VOLTAGE, nicheless light fittings from major brands.

For safe and proper installation, please read this manual in full before commencing installation and use only the parts (screws, plugs, sealant etc) as provided.

For operating instructions, please refer to the MULTI PLUS Installation & User Guide.

- For safe and proper installation, ensure that only those parts supplied with the system are used.
- Maximum installation depth for the **Retro T1** light is 20" below water line (to top of light).
- The **Retro T1** light must be correctly installed in or on the wall of the pool with the top of the lens no less than **4"** below the nominal water level.
- All lights should be mounted in a location that is easily accessible without the need for entering or lowering the pool water.
- If cleaning the product is required, only use warm water and a soft brush or cloth to clean **Retro T1** lights. **DO NOT** use detergents or spirits as this can damage the light and void your warranty.
- Operating the light for at least 30 minutes every week is advised (unless removed and stored safely for winter months).
- **Retro T1** lights are suited for both domestic and commercial installations and can be operated continuously (24/7) if required.
- Temperature range for installation, operation and servicing: +32°F ~ +104°F (0°C ~ +40°C)

WARNING



- The **Retro T1** Light must be water cooled at all times. DO NOT switch the light on until installation is complete and the light is fully submerged in water.
- Ensure only circular cable not exceeding 15/32" (12mm) diameter is connected to the **Retro T1** Light. The use of Fig. 8 or non circular cable will not seal correctly & will void the product warranty.
- The **Retro T1** LED Light does not contain any user serviceable parts, opening the light will void the product warranty.
- Pool chemicals & PH levels: Due to the corrosive nature of unbalanced pool chemicals, Spa Electrics strongly recommend that your pool water is balanced prior to installing your pool Lights or any plastic or stainless steel components, and tested weekly to maintain these levels. pH levels should be maintained between 7.2- 7.6 at all times to ensure the longevity of these components.
 - Failure to do so can result in chemical damage to the light housing and pool fittings, including stainless steel components.
 - Please note: Lights or components found to have excessive chemical damage will not be covered under our manufacturer's warranty policy

TOOLS REQUIRED

✓ Draw wire

✓ Small flat-blade screw driver

✓ Pliers or side cutters

IMPORTANT NOTES



- The use of power tools during installation is **not** recommended as these devices can cause faults and damage to light components.
- All installation steps should be carried out with manual tools only.
- The enclosed images are for illustrative purposes only. Appearances of parts and assemblies may vary from the enclosed illustrations
- Please contact Spa Electrics or contact us below if you have any questions regarding the correct installation of this product.

PRODUCT SUPPORT AND INFORMATION

For the most up to date installation information and contact information for assistance in your region, please visit www.spaelectrics.com

INCLUDED PARTS

GLOBRITE RETRO ADAPTER KIT (P/N: T1G 005)

GLOBRITE ADAPTER ASSEMBLY

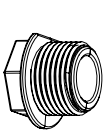

CABLE
NUT



CABLE
WASHER



GLAND
(2x sizes)

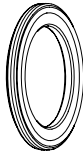

ADAPTER
GASKET

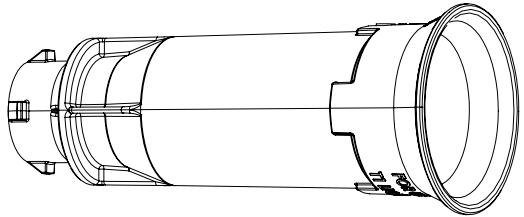

GLOBRITE ADAPTER

PLUG ASSEMBLY (P/N: T1 003)

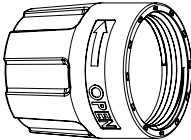

PLUG COLLAR

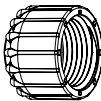

GLAND NUT



GLAND
(2x sizes)

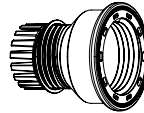

CONNECTOR
BARREL

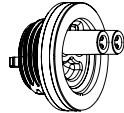

SCREW
TERMINAL END
(Screws attached)

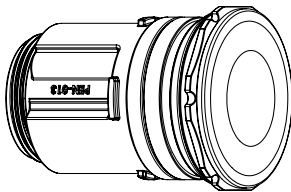

LIGHT ASSEMBLY

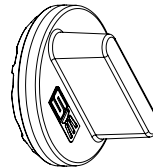

LIGHT INSTALLATION
TOOL
(P/N: T1 018)

REQUIRED PART (NOT INCLUDED)



UL LISTED ISOLATING LOW VOLTAGE POWER SUPPLY, EVALUATED FOR SWIMMING POOL USE.

Installed as per current NEC wiring rules. 12~14v AC output. Minimum 8W per Retro Series Pool Light. Spa Electrics recommends "LVX" safety transformers for use with Retro Universal lights

1: REMOVE EXISTING LIGHT

**STOP! WARNING
ELECTROCUTION**

CHECK POWER
IS TURNED OFF
FIRST

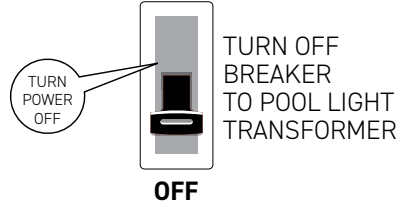

OFF

1.1 REMOVE EXISTING LIGHT

- 1: REMOVE EXISTING LIGHT FROM THE GLOBRITE FITTING AND BRING ABOVE THE WATER LINE.
- 2: CUT POWER CABLE AS CLOSE TO BACK OF EXISTING LIGHT AS POSSIBLE.

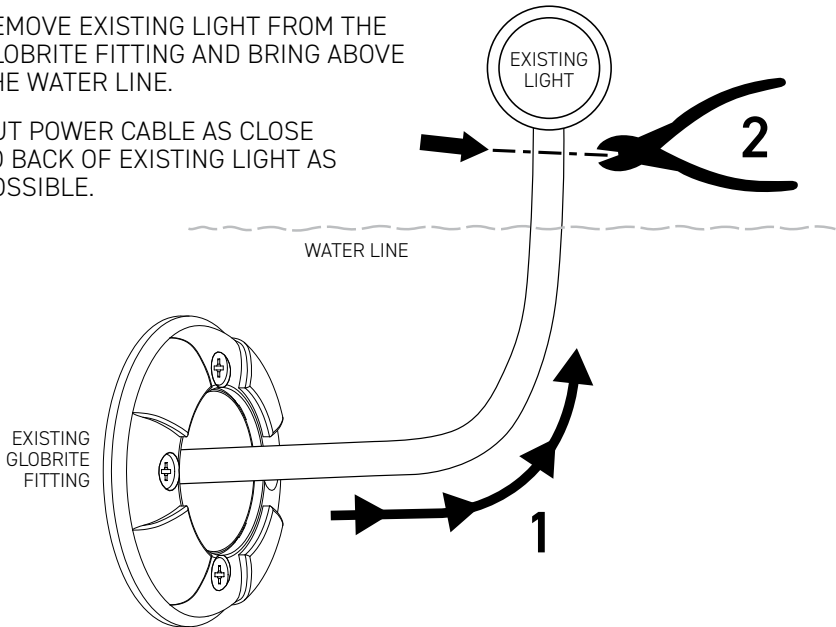

IMPORTANT NOTE



ALL CABLE & PLUG CONNECTIONS ARE TO BE DONE AT SURFACE LEVEL, AND OUT OF WATER.

IF EXISTING CABLE IS NOT LONG ENOUGH TO BRING ABOVE WATER LINE, THE CABLE WILL NEED TO BE DRAWN THROUGH CONDUIT/PIPE. ENSURE APPROPRIATE MEASURES ARE TAKEN TO PULL BACK CABLE FOR RE-CONNECTION.

FOR COLDER CLIMATES, IT IS RECOMMENDED TO LOWER THE WATER LEVEL TO BELOW THE EXISTING LIGHT TO AVOID TRAPPING WATER IN THE PIPE DURING INSTALLATION.

1.2 CABLE PREPARATION

STRIP THE END OF THE EXISTING POWER CABLE TO SPECIFIED LENGTH.

NOTE



IF CABLE LENGTH ALLOWS, CUT CABLE BACK UNTIL FRESH COPPER APPEARS.

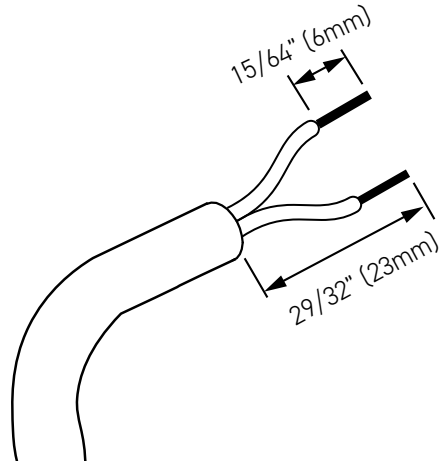

ALL CABLE & PLUG CONNECTIONS ARE TO BE DONE AT SURFACE LEVEL, AND OUT OF WATER.

2: GLOBRITE ADAPTER ASSEMBLY

2.1 FEED PARTS ONTO THE EXISTING CABLE

FEED THE **CABLE NUT** ONTO THE CABLE, THEN FEED THE **CABLE WASHER** ONTO THE CABLE.

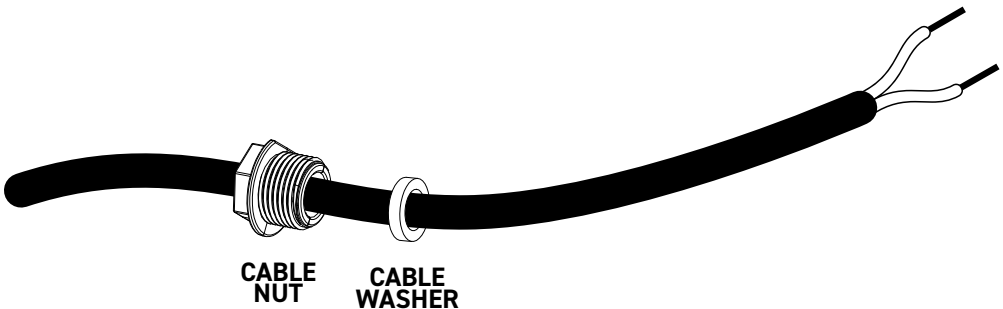

2.2

CABLE GLAND

SELECT THE CORRECT SIZED CABLE GLAND FROM THE 2 INCLUDED SIZES:

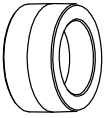

SUITS 23/64" (9mm) CABLE OD
COLOR: TEAL
FOR USE WITH EXISTING
GLOBRITE CABLE

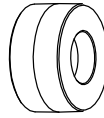

SUITS 19/64" (7.5mm) CABLE OD
COLOR: PURPLE
FOR USE WITH EXISTING
MICROBRITE CABLE

FEED THE CABLE GLAND ONTO THE CABLE.

THE GLAND FITMENT SHOULD BE FIRM OVER THE CABLE
WITHOUT BULGING OR DEFORMING THE GLAND.



GLAND

2.3

FIT THE GLOBRITE GASKET

FIT THE ADAPTER GASKET OVER THE BACK OF THE GLOBRITE ADAPTER.

NOTE: THE GASKET WILL SIT LOOSELY IN THIS POSITION UNTIL INSTALLED INTO
THE EXISTING FITTING.

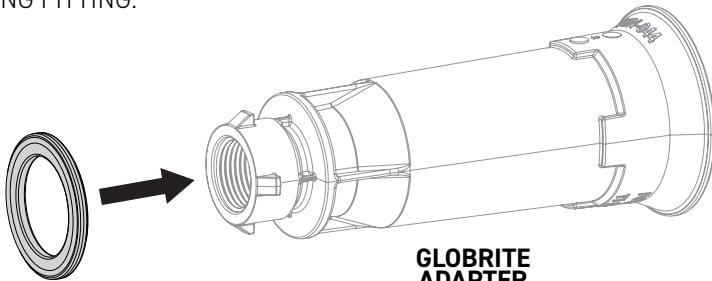

ADAPTER
GASKET

GLOBRITE
ADAPTER

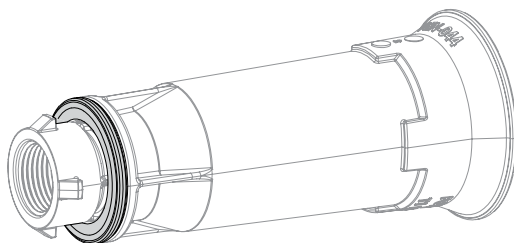

2.3

FEED GLOBRITE ADAPTER ONTO CABLE

FEED THE GLOBRITE ADAPTER ONTO THE CABLE.

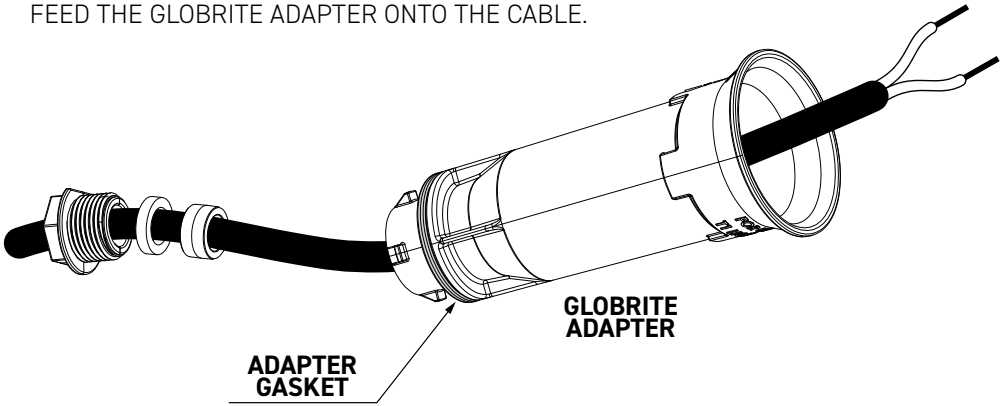

2.4

FIT THE GLAND, WASHER & NUT

1: FEED AND SEAT INTO POSITION THE GLAND, CABLE WASHER, AND CABLE NUT INTO THE BACK OF THE GLOBRITE ADAPTER.

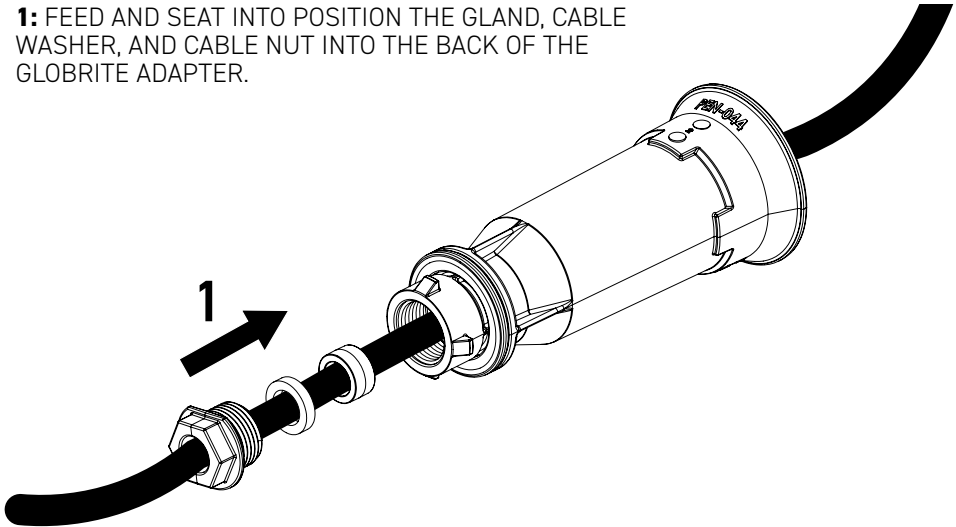

2.4 FIT THE GLAND, WASHER & NUT ...CONTINUED

2: LOOSELY THREAD THE CABLE NUT INTO THE BACK OF THE GLOBRITE ADAPTER. DO NOT FULLY TIGHTEN. THIS NUT WILL BE TIGHTENED IN A LATER STEP.

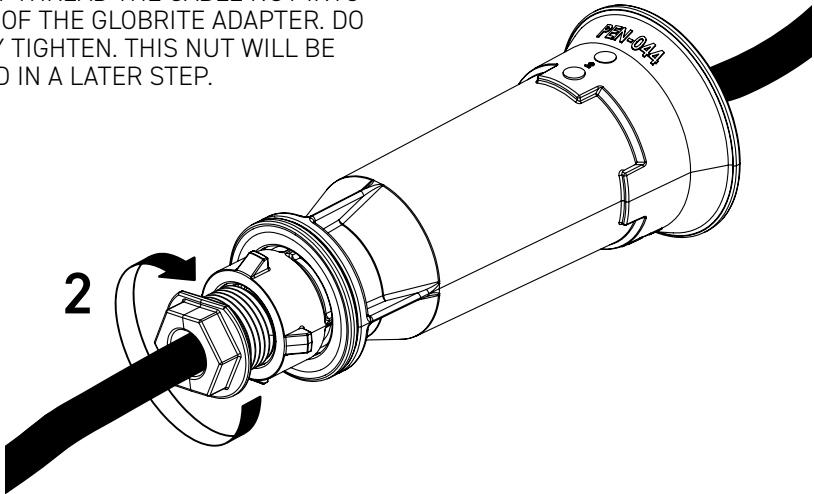

2.5 OVERVIEW OF CURRENT PROGRESS

OVERVIEW OF THE INSTALLATION PROGRESS OF THE GLOBRITE ASSEMBLY, EXISTING FITTING, AND THE CABLE:

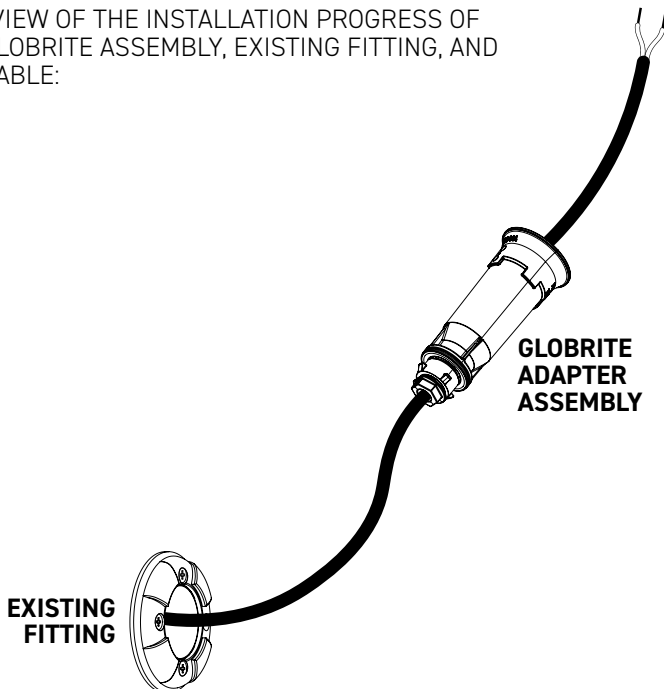

3: PLUG ASSEMBLY

3.1 FEED PARTS ONTO THE CABLE

FEED THE PLUG COLLAR ONTO THE CABLE, THEN FEED THE GLAND NUT ONTO THE CABLE.

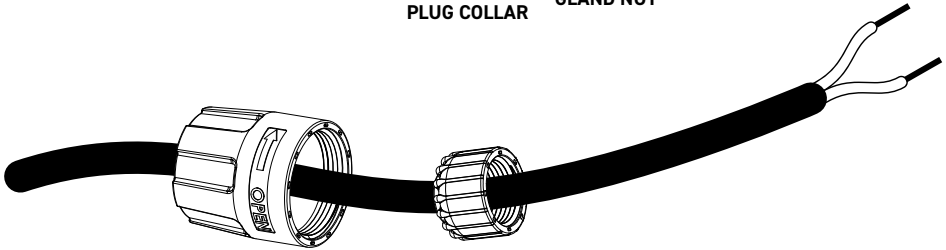
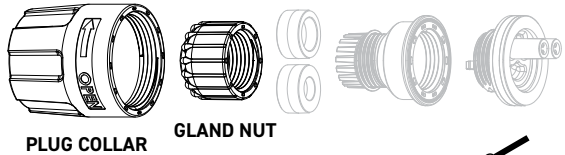

3.2 CABLE GLAND

SELECT THE CORRECT SIZED CABLE GLAND FROM THE 2 INCLUDED SIZES:

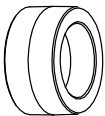
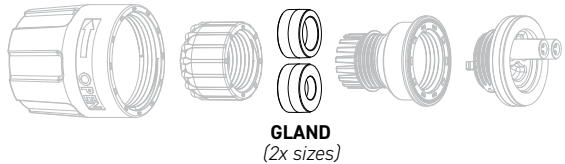

SUITS 23/64" (9mm) CABLE OD
COLOR: TEAL
FOR USE WITH EXISTING
GLOBRITE CABLE

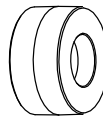

SUITS 19/64" (7.5mm) CABLE OD
COLOR: PURPLE
FOR USE WITH EXISTING
MICROBRITE CABLE

FEED THE CABLE GLAND ONTO THE CABLE.

THE GLAND FITMENT SHOULD BE FIRM OVER THE CABLE WITHOUT BULGING OR DEFORMING THE GLAND.

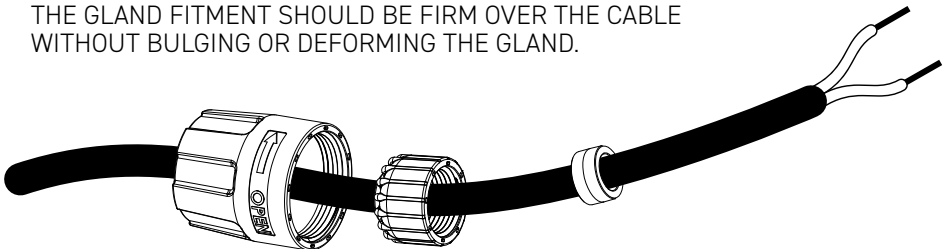

3.3

FEED CONNECTOR BARREL ONTO CABLE

FEED THE CONNECTOR BARREL ONTO THE CABLE.

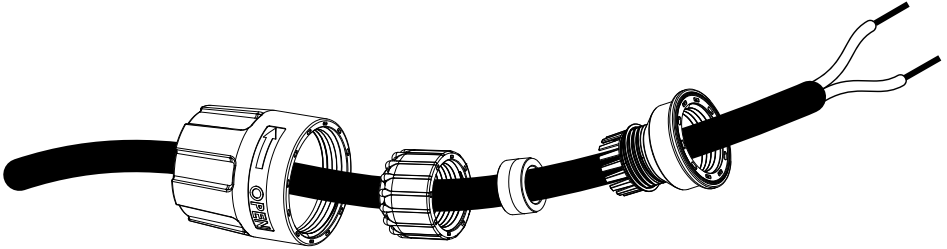
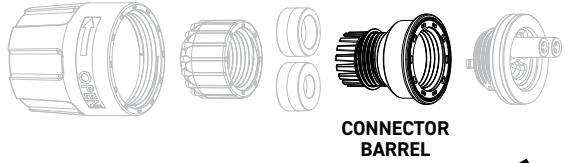

3.4

CONNECT THE SCREW TERMINAL END

- 1: USING A FLAT HEAD SCREWDRIVER, LOOSEN THE TWO (2) FASTENERS ON THE SCREW TERMINAL END. DO **NOT** FULLY REMOVE THE TWO FASTENERS.

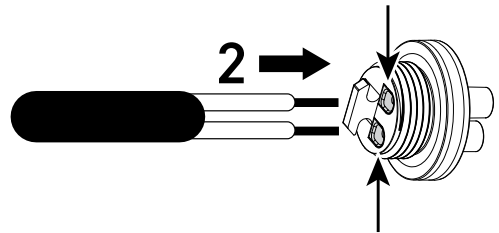
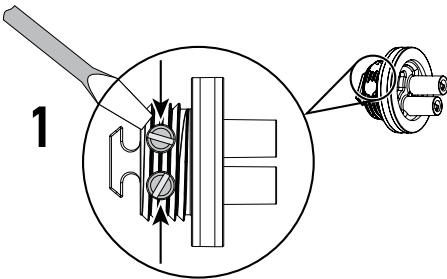
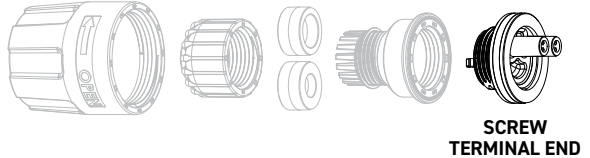

- 2: FEED THE TWO STRIPPED CABLE ENDS THROUGH THE TWO HOLES IN THE BACK OF THE SCREW TERMINAL END.
- 3: USE A FLAT HEAD SCREWDRIVER TO RE-TIGHTEN THE TWO (2) FASTENERS.

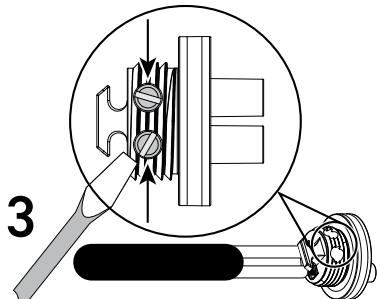

3.5 STRAIN RELIEF

ADJUST THE TWO CABLE ENDS SO THAT THEY SIT BEHIND THE STRAIN RELIEF POST AS SHOWN IN THE THREE ILLUSTRATIONS BELOW.

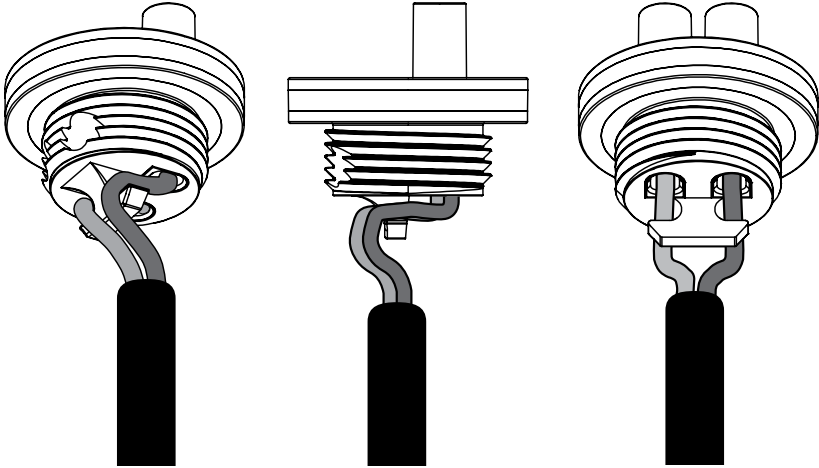

3.6 ATTACH CONNECTOR BARREL

1: FEED THE CONNECTOR BARREL ONTO THE SCREW TERMINAL END.

2: CAREFULLY THREAD THE CONNECTOR BARREL ON AND TIGHTEN FIRMLY BY HAND.

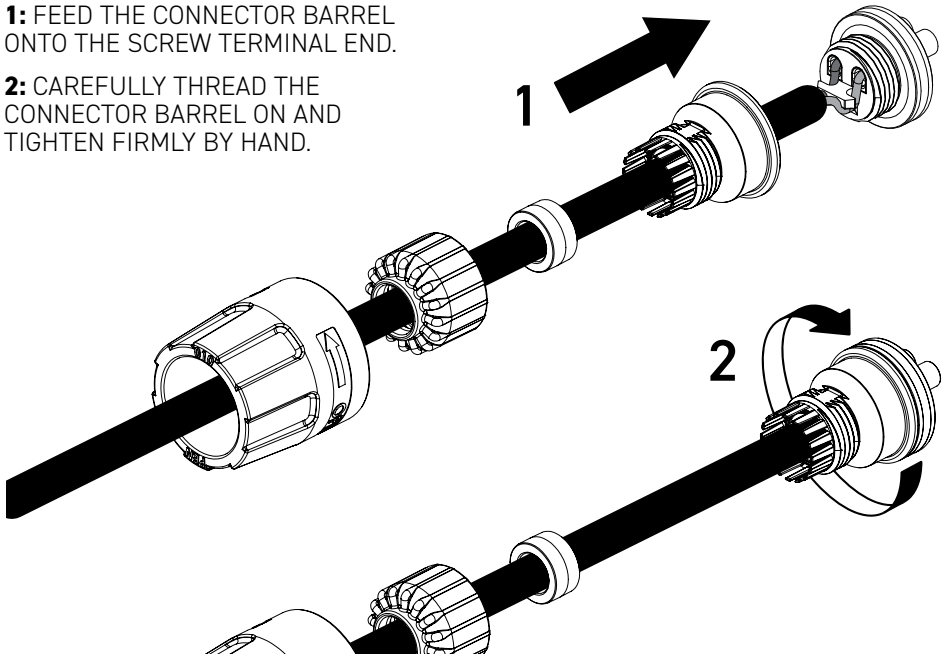

3.7

CONTINUE ASSEMBLY OF REMAINING PARTS

- 1: SEAT THE CABLE GLAND ALL THE WAY INTO THE BACK OF THE CONNECTOR BARREL (DO A VISUAL CHECK TO MAKE SURE THERE IS A SEAL BETWEEN THE GLAND AND CABLE).
- 2: CAREFULLY FEED THE GLAND NUT ONTO CONNECTOR BARREL.
- 3: TIGHTEN THE GLAND NUT FIRMLY, BY HAND ONLY. BE CAREFUL TO **NOT** CROSS-THREAD.

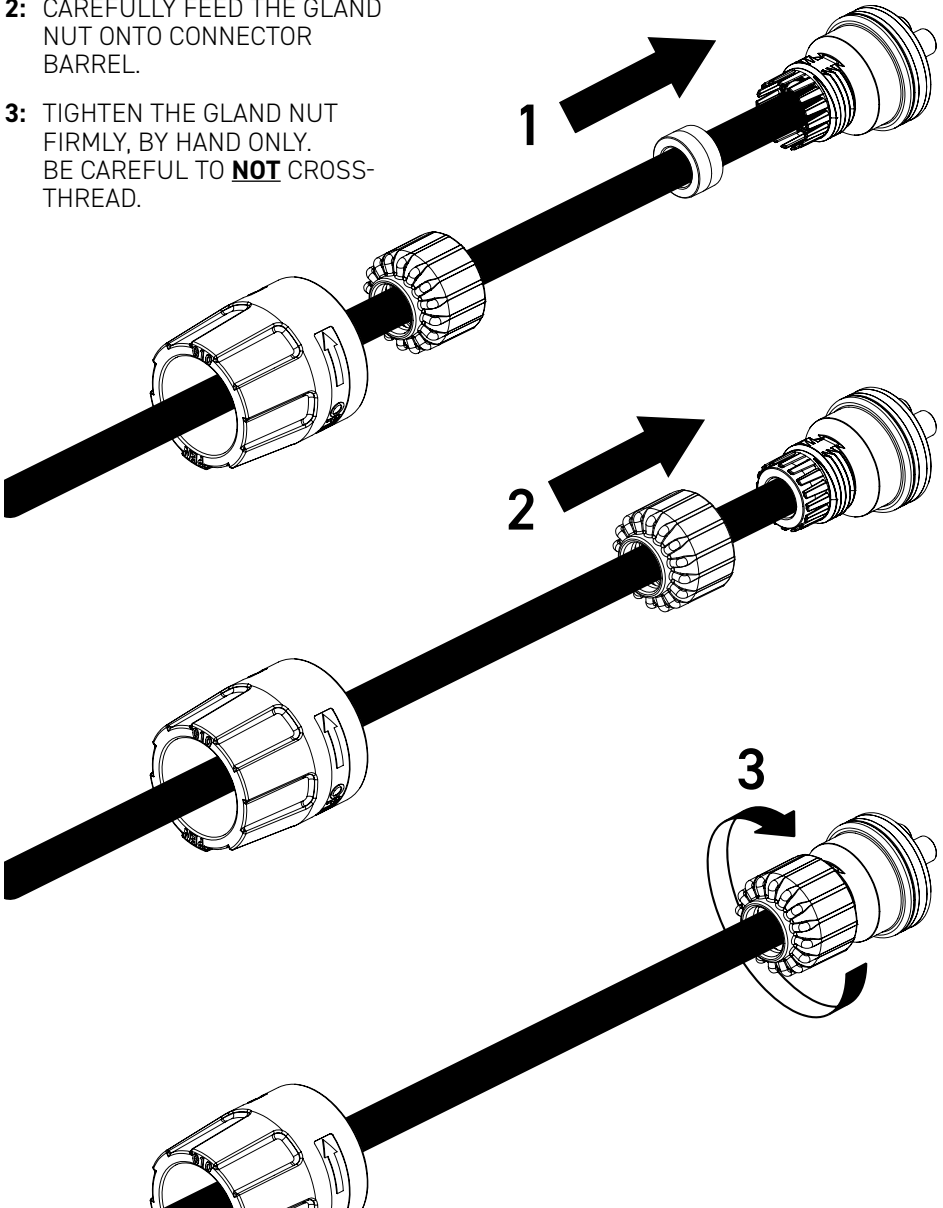

3.8

COMPLETE ASSEMBLY OF PLUG

POSITION PLUG COLLAR ALL THE WAY TO THE END READY FOR ATTACHMENT TO THE LIGHT ASSEMBLY.

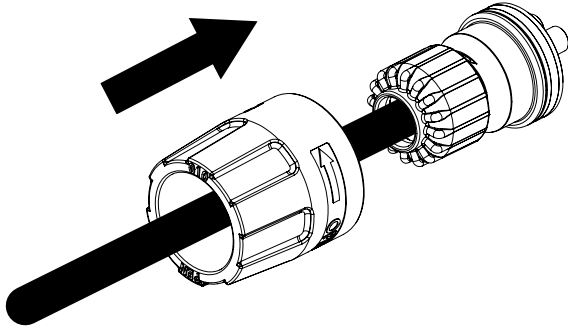

COMPLETED PLUG ASSEMBLY

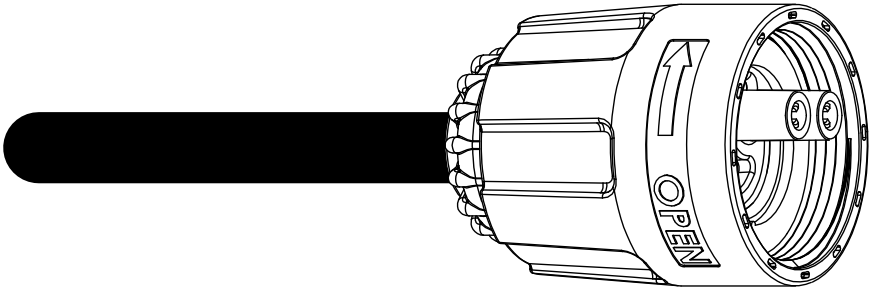

3.9

OVERVIEW OF CURRENT PROGRESS

OVERVIEW OF THE INSTALLATION PROGRESS OF THE PLUG ASSEMBLY, GLOBRITE ASSEMBLY, EXISTING FITTING, AND THE CABLE:

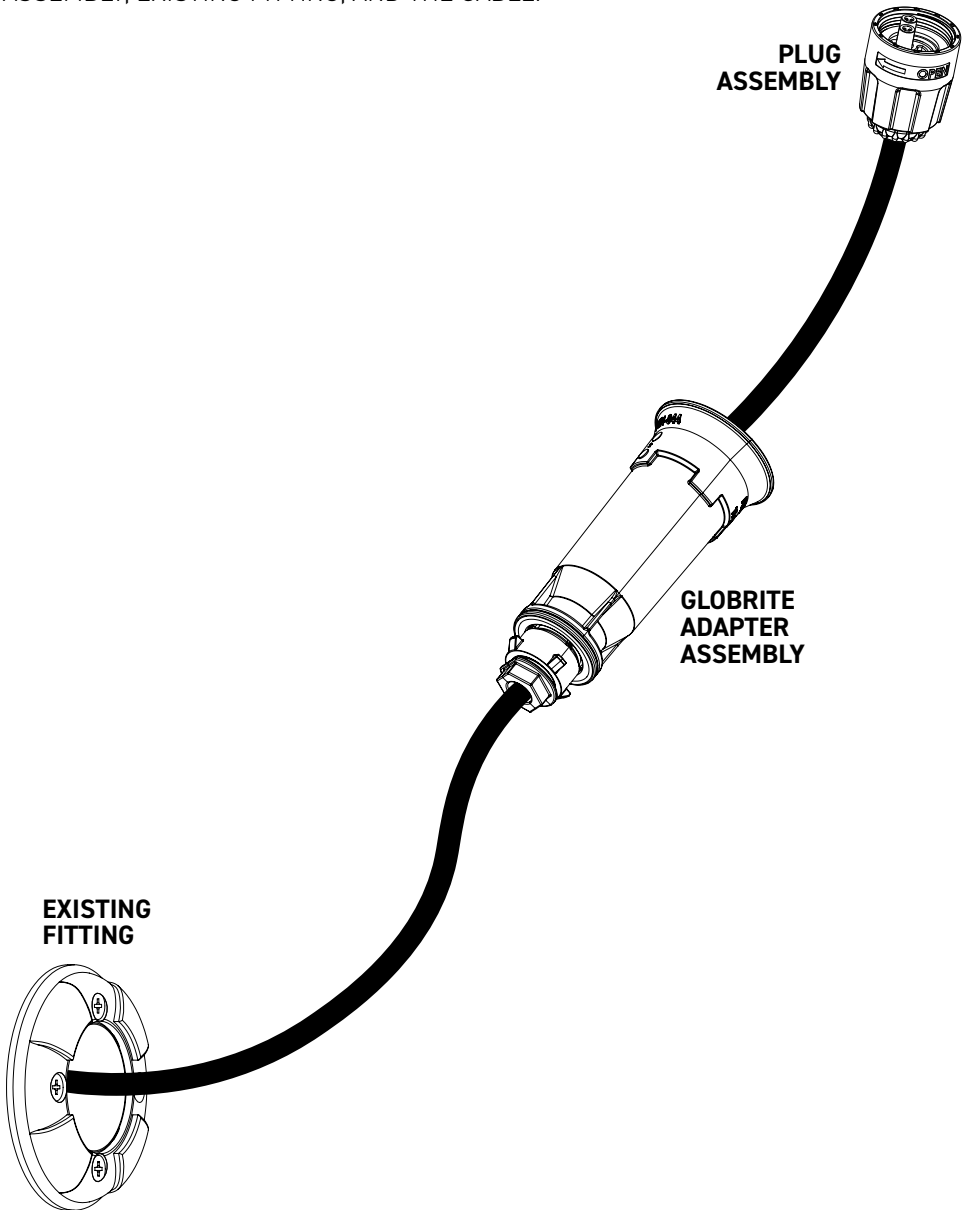

4: LIGHT ASSEMBLY

4.1 CONNECT THE TERMINALS

ALIGN THE TERMINAL PINS ON THE PLUG AND BACK OF THE LIGHT ASSEMBLY AND FIRMLY CONNECT TOGETHER.

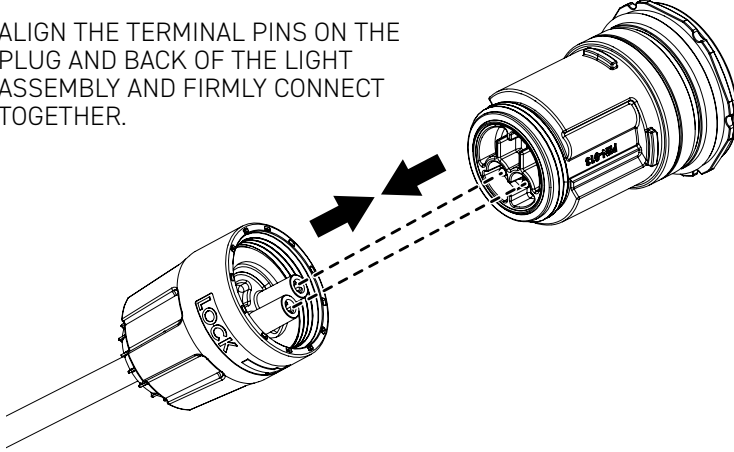

4.2 FASTEN PLUG TO LIGHT

TO LOCK INTO PLACE:
TWIST COLLAR CLOCKWISE A FEW
TIMES UNTIL IT'S HAND TIGHT.

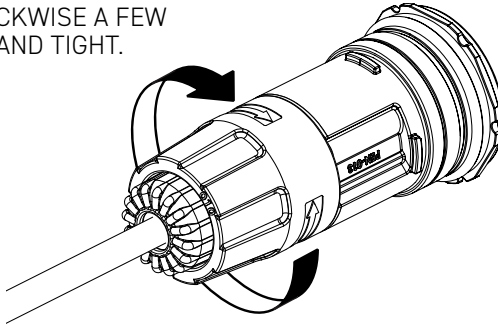

4.3

SLIDE GLOBRITE ADAPTER OVER LIGHT ASSEMBLY

SLIDE THE GLOBRITE ADAPTER UP THE CABLE AND OVER THE LIGHT ASSEMBLY.

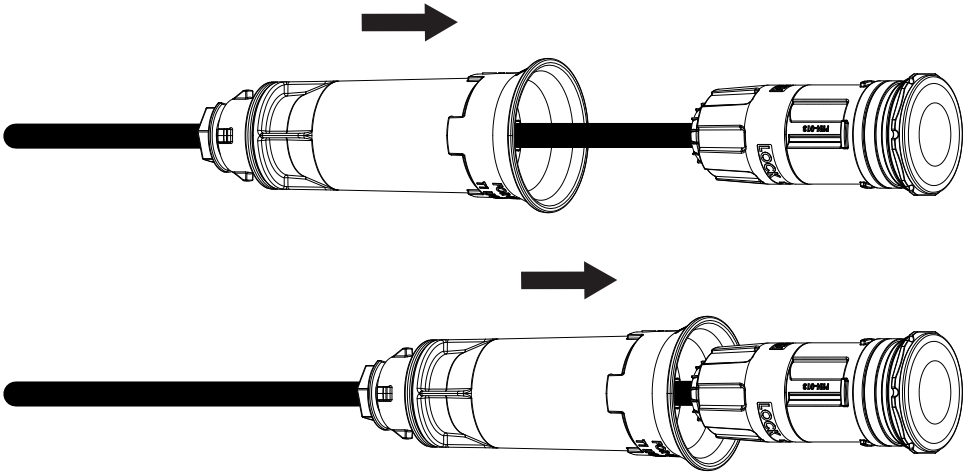

ENSURE THE LIGHT ASSEMBLY IS FULLY INSERTED INTO THE GLOBRITE ADAPTER. THE LIGHT ASSEMBLY SHOULD NOT BE PROTRUDING FROM THE FRONT OF THE GLOBRITE ADAPTER.



NOTE: ENSURE THE 4 ALIGNMENT TABS ON THE LIGHT ASSEMBLY LINE UP WITH 4 SLOTS ON THE GLOBRITE ADAPTER.

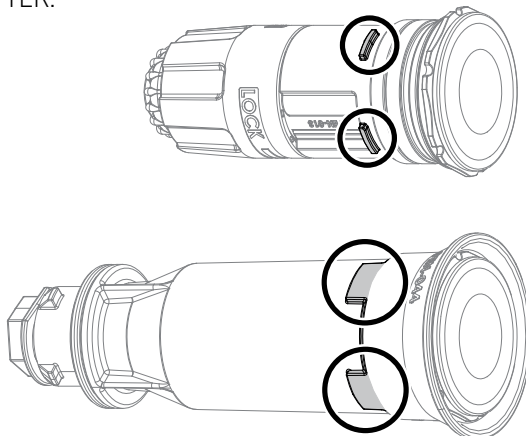

4.4 TIGHTEN CABLE NUT

PULL ON THE CABLE WHILE HOLDING THE GLOBRITE ADAPTER TO REMOVE ANY SLACK CABLE THAT MAY BE INSIDE THE ADAPTER.

THEN TIGHTEN THE CABLE NUT UNTIL FIRMLY SEATED USING A SUITABLE WRENCH/ SPANNER.

[SIZE: 19mm (3/4" equivalent)]

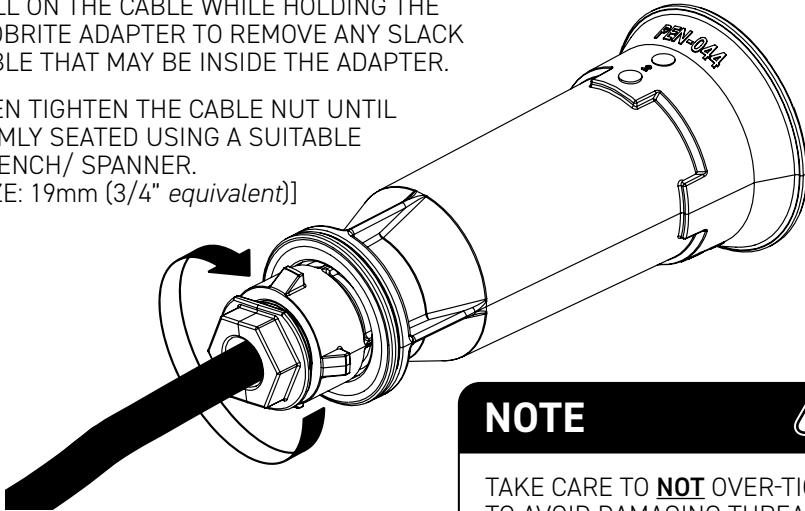

NOTE



TAKE CARE TO **NOT** OVER-TIGHTEN TO AVOID DAMAGING THREAD AND PLASTIC.

4.5 OVERVIEW OF CURRENT PROGRESS

OVERVIEW OF THE INSTALLATION PROGRESS OF THE GLOBRITE ADAPTER WITH LIGHT ASSEMBLY, EXISTING FITTING, AND THE CABLE:

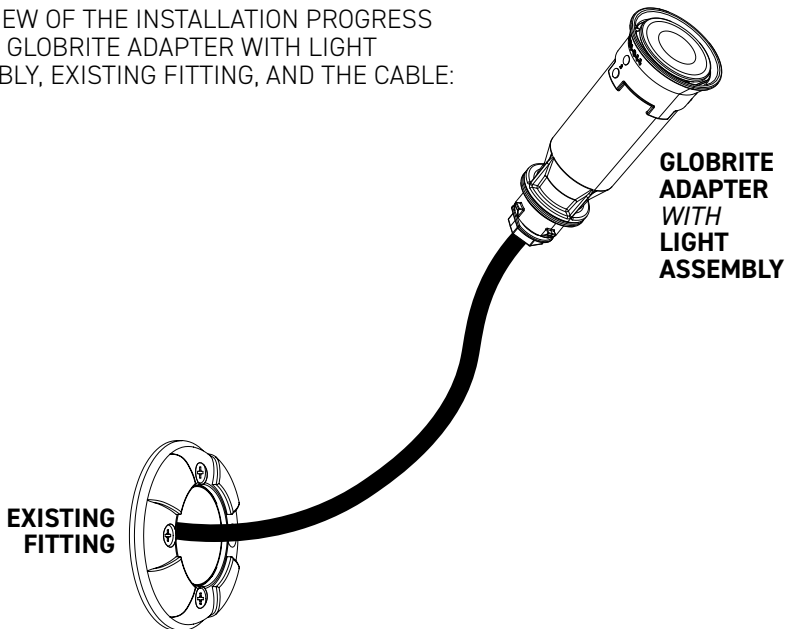

5: FITMENT INTO EXISTING FITTING

5.1 INSERT ASSEMBLY INTO EXISTING FITTING

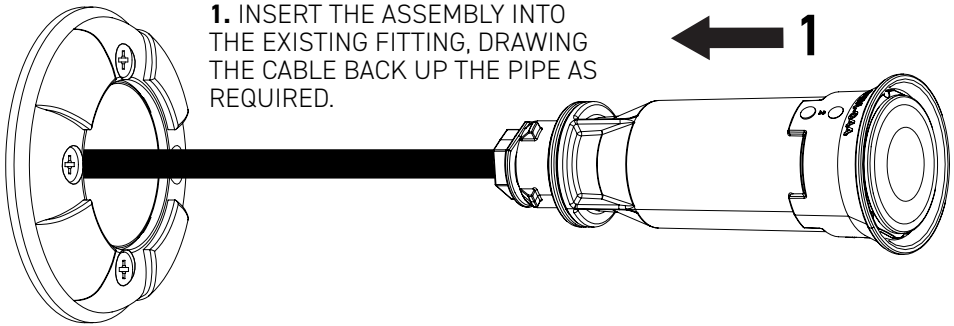

1. INSERT THE ASSEMBLY INTO THE EXISTING FITTING, DRAWING THE CABLE BACK UP THE PIPE AS REQUIRED.

2. THERE IS A BAYONET FEATURE IN THE BACK OF THE EXISTING FITTING. YOU MAY NEED TO TURN THE ASSEMBLY EITHER CLOCKWISE OR COUNTER-CLOCKWISE AS YOU PUSH IT INTO THE FITTING TO ALIGN THE FEATURES INDICATED BELOW.

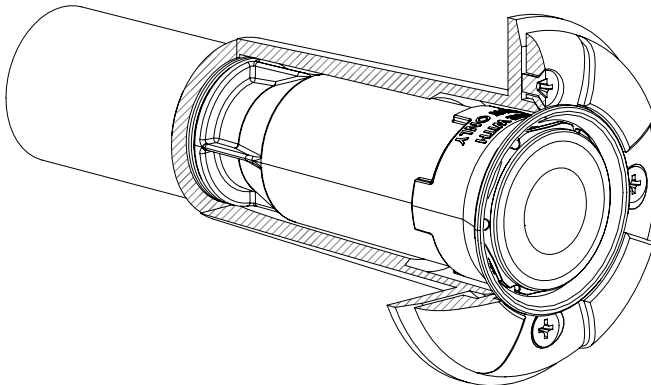
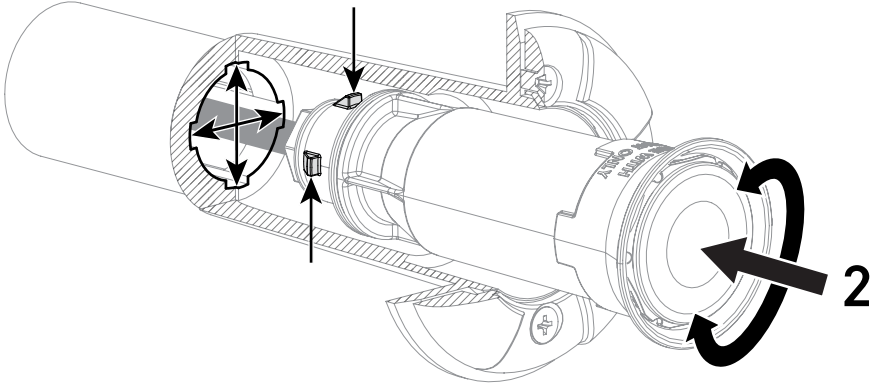

IF THE FEATURES ARE ALIGNED CORRECTLY, YOU WILL BE ABLE TO PUSH THE ASSEMBLY ALL THE WAY IN UNTIL FULLY SEATED AND FLUSH WITH THE FRONT OF THE GLOBRITE FITTING.

5.2 LOCK ASSEMBLY INTO PLACE

1. INSERT THE INSTALLATION TOOL INTO THE FRONT OF THE ASSEMBLY, ALIGNING THE FEATURES ON THE TOOL WITH THE FRONT OF THE LIGHT.
2. TWIST THE ASSEMBLY 45 DEGREES CLOCKWISE WITH THE TOOL TO LOCK THE ASSEMBLY IN PLACE.

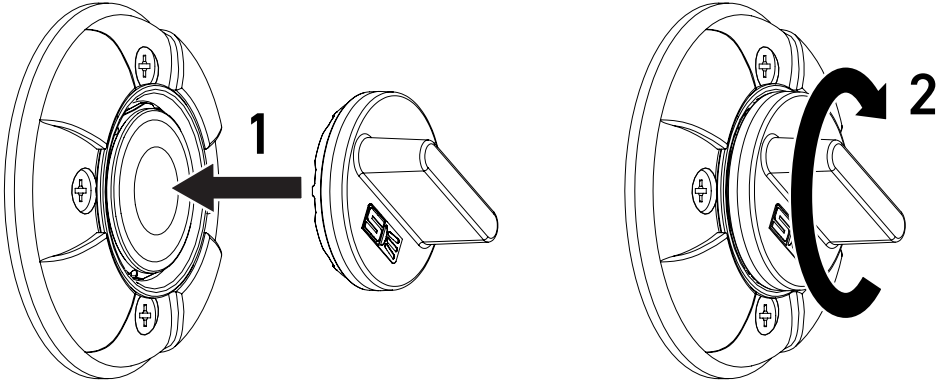

INSTALLATION COMPLETED

WINTERIZATION

IN COLDER CLIMATES, IT IS HIGHLY RECOMMENDED TO LOWER THE WATER LEVEL TO BELOW THE LIGHTS TO AVOID DAMAGE TO THE LIGHT ASSEMBLY AND THE SUPPORTING FIXTURES.

ANY DAMAGE CAUSED BY IMPROPER WINTERIZATION WILL NOT BE COVERED UNDER WARRANTY BY SPA ELECTRICS.

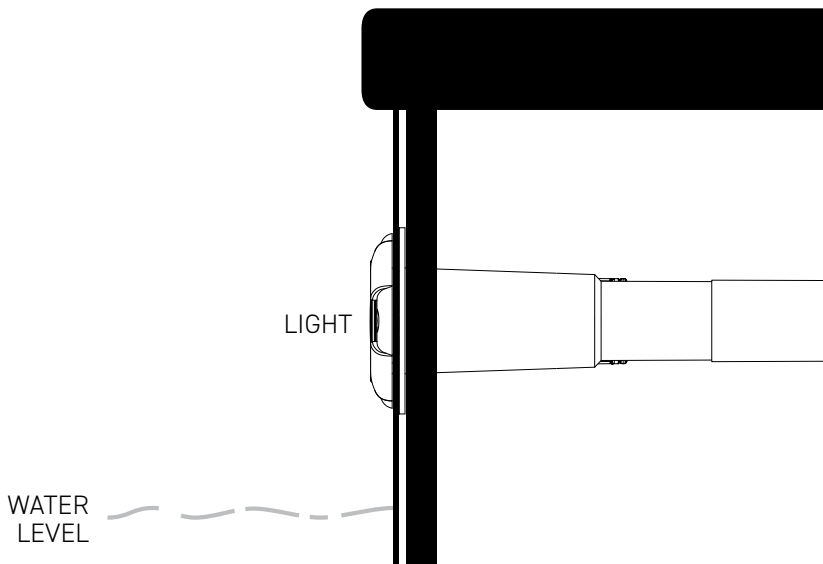

LIGHT REMOVAL

1 UNLOCK ASSEMBLY

1. INSERT THE INSTALLATION TOOL INTO THE FRONT OF THE ASSEMBLY, ALIGNING THE FEATURES ON THE TOOL WITH THE FRONT OF THE LIGHT.
2. TWIST THE ASSEMBLY 45 DEGREES COUNTER-CLOCKWISE WITH THE TOOL TO UNLOCK THE ASSEMBLY FROM THE GLOBRITE FITTING.

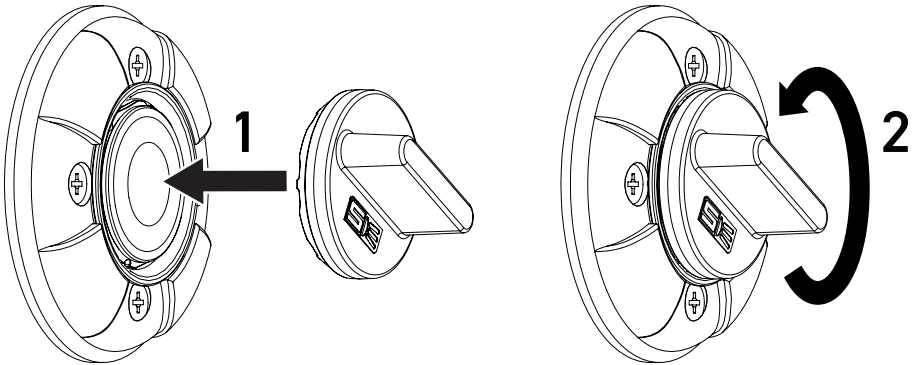

2 PULL ASSEMBLY OUT OF GLOBRITE FITTING

- PULL THE ASSEMBLY OUT OF THE GLOBRITE FITTING, DRAWING THE CABLE FROM THE TRANSFORMER SIDE THROUGH TO THE POOL SIDE.
- IF NEEDED, A FLAT-HEAD SCREWDRIVER MAY BE USED TO ASSIST IN LIGHTLY PRYING THE ASSEMBLY OUT OF THE GLOBRITE FITTING.

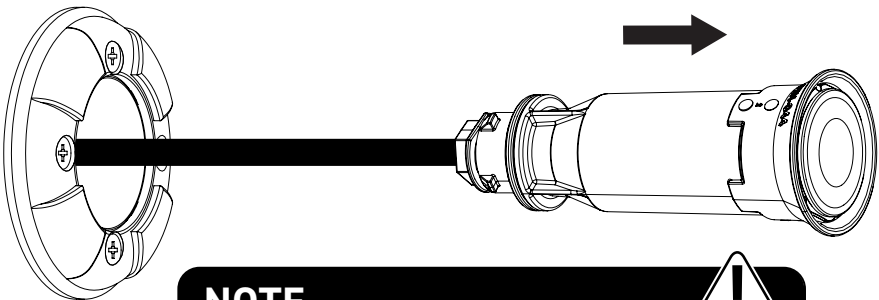

NOTE



IF A TOOL IS USED, ENSURE CARE IS TAKEN NOT TO SCRATCH OR DAMAGE THE FRONT OF THE LIGHT.

3

CHECK FOR ADAPTER GASKET

CHECK THAT THE ADAPTER GASKET IS IN POSITION ON THE BACK OF THE GLOBRITE ADAPTER AS SHOWN.

IF NOT, THE GASKET WILL LIKELY BE INSIDE THE BACK OF THE GLOBRITE FITTING. ENSURE THAT THE GASKET IS REMOVED FROM THIS FITTING AND PLACED ONTO THE ADAPTER. YOU MAY NEED TO USE A LONG FLAT-HEAD SCREWDRIVER TO UN-STICK THE GASKET FROM THE BACK OF THE FITTING.

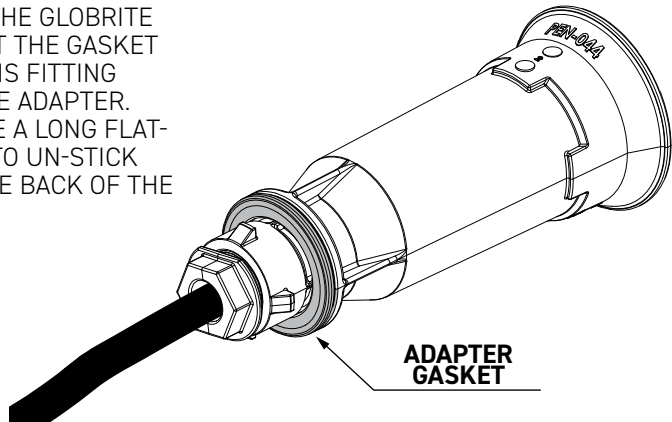

4

LOOSEN CABLE NUT

LOOSEN THE CABLE NUT ON THE BACK OF THE GLOBRITE ADAPTER USING A SUITABLE WRENCH/ SPANNER [SIZE: 19mm (3/4" equivalent)].

NOTE: IT IS **NOT** NECESSARY TO FULLY UNDO THE CABLE NUT, ONLY LOOSEN.

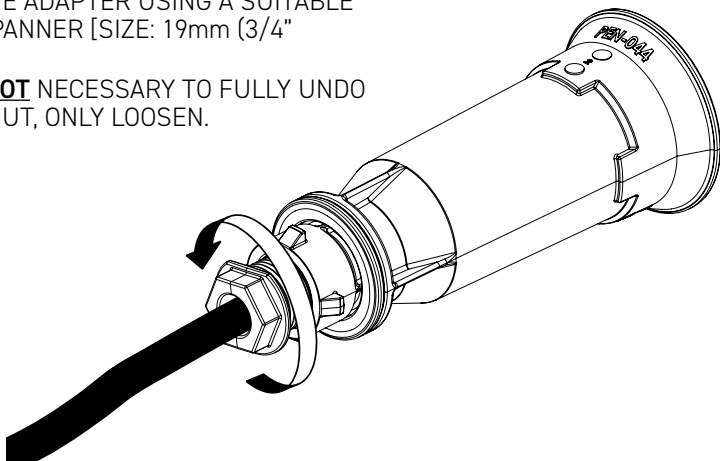

5

SLIDE GLOBRITE ADAPTER DOWN CABLE

WHILE HOLDING ONTO THE CABLE CLOSE TO THE BACK OF THE GLOBRITE ADAPTER, SLIDE THE GLOBRITE ADAPTER DOWN THE CABLE, REVEALING THE LIGHT ASSEMBLY.

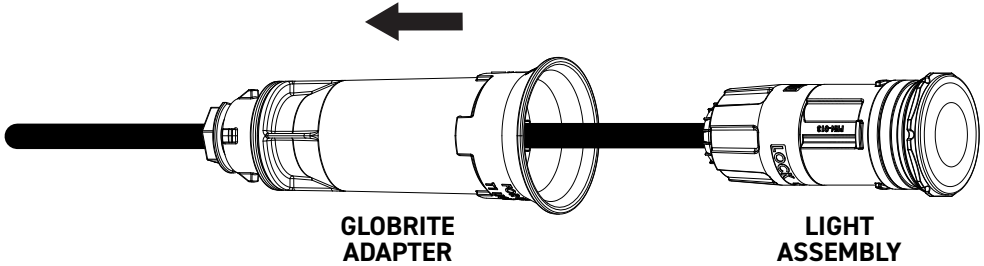

6

DETACH LIGHT ASSEMBLY FROM PLUG

1. UNSCREW THE PLUG COLLAR COUNTER-CLOCKWISE UNTIL IT IS FREE SPINNING.

IMPORTANT



CABLE SHOULD BE SECURED ABOVE WATER AND WEATHER PROTECTED WHILE LIGHT IS DETACHED.

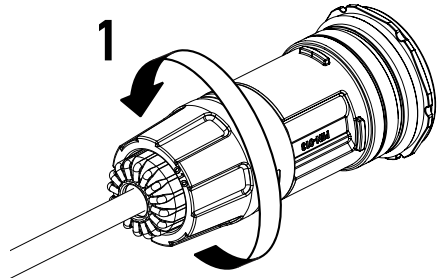

2. DISCONNECT LIGHT ASSEMBLY FROM PLUG BY PULLING APART.

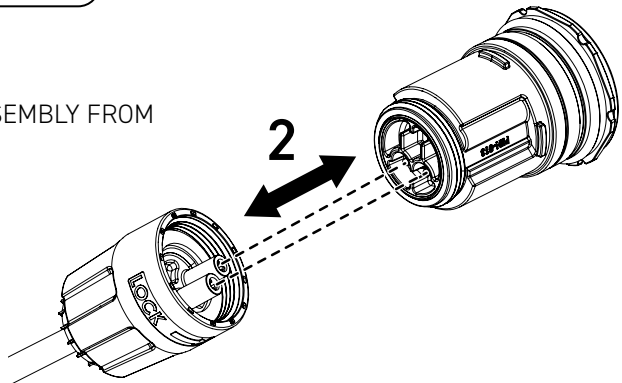

KEY DIMENSIONS

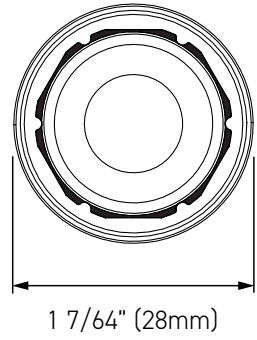
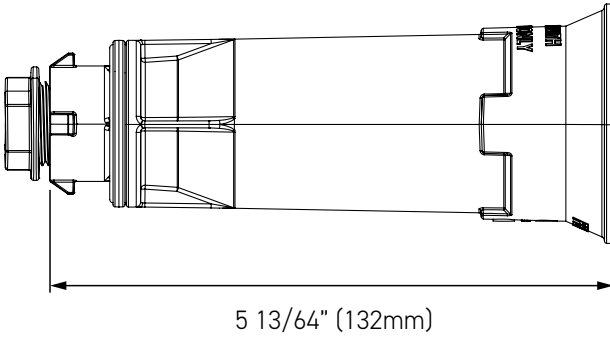

TROUBLESHOOTING

ISSUE	REASON	ACTION
Light returns to WHITE color during manual color change	Light synchronization process has been triggered	Refer to MULTI PLUS Installation & User Guide
Light flashes 2 times (RED)	Light over heating.	Check light is fully submerged. Check vents are not obstructed
Light not operating (1)	Faulty connection to transformer	Ensure low voltage cable is correctly connected to transformer terminals
Light not operating (2)	Main power not connected	Check transformer is connected to Main power (hardwired or plugged into a certified outlet) and the breaker is switched on
Light not operating (3)	Damaged cable	Disconnect plug top and test voltage under load using multi-meter (ie. 20w 12v)
Light not operating (4)	Transformer not working	Check fuses & test transformer using multimeter under load (ie.15W 12V)
Light colors not synchronized	Incorrect operating mode selected.	Refer to MULTI PLUS setup procedure

If these issues cannot be resolved with the above recommended actions, please contact your local Spa Electrics reseller or Spa Electrics directly.

www.spaelectrics.com

ELECTRICAL GROUNDING

Underwriters Laboratories (UL) Statement

Per the NEC, NFPA 70, Article 680.23 (B)(5), states that bonding shall not be required for luminaires that are listed for the application and have no non-current carrying metal parts. In addition, per Article 680.26 (B)(4), exception states that Listed low-voltage lighting systems with non-metallic forming shells shall not require bonding.

Therefore, luminaires with polymeric/non-current carrying metal parts are not required to be grounded / bonded.

Manufacturers Statement

Spa Electrics **Retro T1** luminaires with their plastic housing designs do not require grounding / bonding.

Spa Electrics **Retro T1** lights have also been determined to comply with the applicable requirements for wet-niche, LED type Swimming Pool and Spa Luminaires.

FCC COMPLIANCE STATEMENT

This device complies with part 15 of the FCC rules. Operation is subject to the following two (2) conditions:

1. This device may not cause harmful interference, and
2. This device must accept any interference received, including interference that may cause undesired operation.

Note: This equipment has been tested and found to comply with the limits for a Class B digital device, pursuant to part 15 of the FCC Rules. These limits are designed to provide reasonable protection against harmful interference in a residential installation. This equipment generates, uses and can radiate radio frequency energy and, if not installed and used in accordance with the instructions, may cause harmful interference to radio communications. However, there is no guarantee that interference will not occur in a particular installation. If this equipment does cause harmful interference to radio or television reception, which can be determined by turning the equipment off and on, the user is encouraged to try to correct the interference by one or more of the following measures:

- **Reorient or relocate the receiving antenna.**
- **Increase the separation between the equipment and receiver.**
- **Connect the equipment into an outlet on a circuit different to that to which the receiver is connected.**
- **Consult the dealer or an experienced radio / TV technician for help.**

Do not make any changes or modifications to the equipment unless otherwise specified in the manual.

PAGE INTENTIONALLY LEFT BLANK



IMPORTANT NOTE

PLEASE STORE THIS MANUAL IN A SAFE PLACE
FOR FUTURE REFERENCE



 **Spa Electrics[®]**

The underwater lighting specialists

spaelectrics.com

©COPYRIGHT 2026 SPA ELECTRICS INC.
ALL RIGHTS RESERVED

US 2026 03 18